

**PWS1 Series**

**Water Softener Systems**



---

---

**Franklin Water Treatment, LLC.**

12630 US Highway 33 N  
Churubusco, IN 46723

Phone (260) 693-1972 Fax (260) 693-0602

# Table of Contents

<b>Pre-installation Instructions</b>	<b>Page 3</b>
<b>General Installation Instructions</b>	<b>Page 4</b>
<b>Bypass Valve</b>	<b>Page 5 &amp; 8</b>
<b>Installation Instructions</b>	<b>Page 5</b>
<b>Control Valve Programming – Set Time-of-Day</b>	<b>Page 10</b>
<b>Control Valve Programming – Initial Settings</b>	<b>Page 10 - 11</b>
<b>Control Valve Operating Displays</b>	<b>Page 9</b>
<b>Specifications</b>	<b>Page 12 - 13</b>
<b>Component Parts Breakdown</b>	<b>Page 14</b>
<b>Component Parts List</b>	<b>Page 15</b>
<b>Control Valve Breakdown</b>	<b>Page 16</b>
<b>Control Valve Parts List</b>	<b>Page 17</b>
<b>Installation Fitting Assemblies</b>	<b>Page 18 - 20</b>
<b>Troubleshooting Guide</b>	<b>Page 21 - 23</b>
<b>Ten Year Limited Warranty</b>	<b>Page 24</b>

This page intentionally left blank

# Pre-installation Instructions

## Description of the softener

The softener system includes a mineral tank (with gravel, distributor and softener resin), brine tank (with salt shelf, brine well, brine tank lid and safety brine valve), and a meter initiated electronic backwashing control valve with bypass and brine line.

## Successful Application

Softeners are designed to remove hardness minerals (calcium and magnesium) from water by the process of ion exchange. They may also remove small amounts of “clear water” iron (2 ppm or less). Softeners are not designed to remove “red water” iron or bacterial iron. If greater levels of iron, “red water” or iron bacteria are present, an iron filter must precede the softener. Softeners are not designed to remove particulates. If there is any sediment or turbidity present in the water, a backwashing filter with appropriate media must precede the softener. Only specialty tannin softeners are designed to remove tannins and the yellow to tea color from water. Softeners will not reduce hydrogen sulfide (“rotten egg” odor).

## Time of Regeneration

Periodically the control valve will go through regeneration. Regeneration is factory preset to 2:00 A.M. The time of regeneration may be changed if needed (see programming procedures on pages 10-11).

## Location Considerations

The proper location to install the softener will ensure optimum performance and satisfactory water quality. The following factors should be considered in selecting the location of this system.

1. The softener must be installed after the pressure tank (private well system only).
2. The softener should be installed after any iron filter and/or other backwashing filter.
3. If chlorine is present in the supply water a whole house carbon filter should be installed before the softener.
4. The system must not be subject to freezing temperatures
5. Ensure that any in-line filter installed prior to the softener does not restrict the flow or pressure required to backwash the softener.
6. The system should be installed as close as possible (preferably within 15') to an adequate floor or laundry drain capable of handling the backwash cycle volume and flow rate (refer to unit specifications on pages 12 - 13). An air gap should be provided between the drain line and plumbing drain.
7. All water conditioning equipment should be installed at least 10' prior to the water heater. Water temperatures exceeding 100°F can damage the internal components of the control valve and mineral tank. An expansion tank may need to be installed in the line to the water heater in order to allow for thermal expansion and comply with local plumbing codes.
8. Appliances requiring extended periods of continuous or high flow water use (i.e. geothermal heat pumps, swimming pools, lawn irrigation, outside hose bibs, etc.) should bypass all water conditioning equipment unless the equipment has been specifically designed for that purpose.

# General Installation Instructions

## GENERAL INSTALLATION & SERVICE WARNINGS

The softener is not designed to support the weight of plumbing.

Do not use Vaseline, oils, other hydrocarbon lubricants or spray silicone anywhere. A silicone lubricant may be used on black "O" Rings, but is not necessary. *Avoid any type of lubricants, including silicone, on red or clear lip seals.*

*Do not use pipe dope or other sealants on threads.* Teflon® tape must be used on the threads of the 1" NPT inlet and outlet and on the threads for the drain line connection. Teflon® tape is not used on the nut connections or caps because "O" Ring seals are used.

The nuts and caps are designed to be unscrewed or tightened by hand or with the special plastic Service Wrench, (CV3193, not included). If necessary, pliers can be used to unscrew the nut or cap. Do not use a pipe wrench to tighten nuts or caps. *Do not place screwdriver in slots on caps and/or tap with a hammer.*

NOTE: If the plumbing system is used as the ground leg of the electric supply, continuity should be maintained by installing ground straps around any non-conductive plastic piping or bypass used in the installation.

Make sure the softener is not installed backwards. The softener will not function properly if installed backwards and softener resin may be forced into the water lines. Arrows molded into the valve body indicate the direction of flow.

## Site Requirements

- water pressure -- 25-100 psi (1.7 – 6.9 bar)
- water temperature -- 33-100°F (0.5-37.7°C)
- electrical -- 115/120 V, 60 Hz uninterrupted outlet dry locations only
- the tank should be on a firm level surface

## Typical Installation

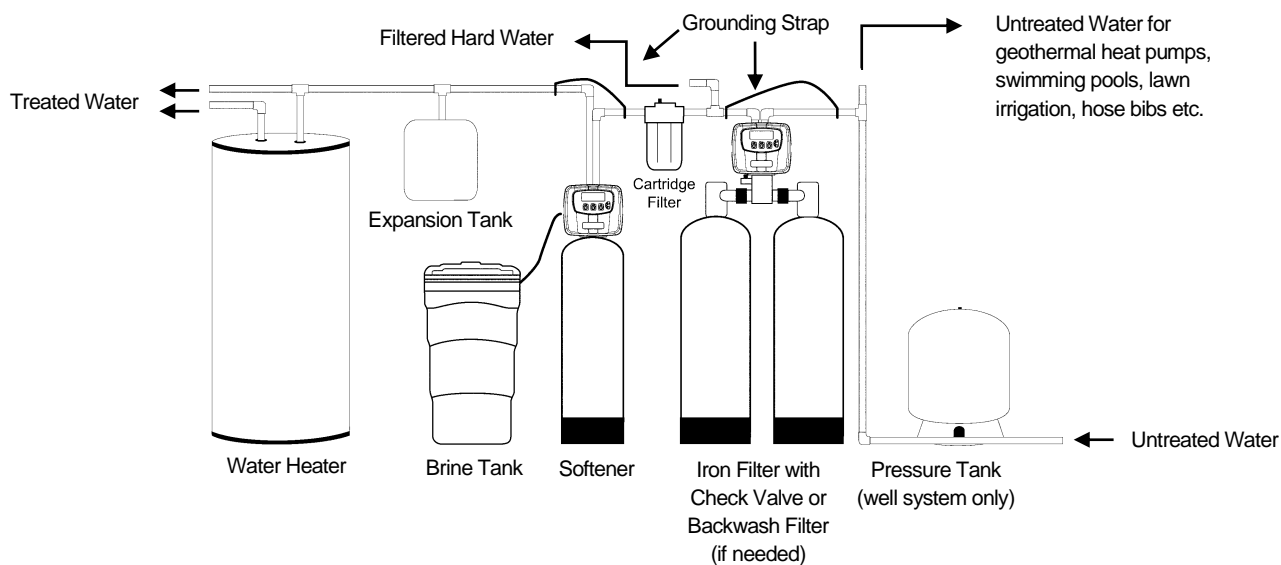

**FIGURE 1: Typical Installation**

# Detailed Installation Instructions

- STEP 1:** Carefully remove all components from packaging. DO NOT DISCARD PACKAGING until all water softener components and fittings have been located.
- STEP 2:** Using the integrated coupling nuts, attach the bypass valve to the inlet/outlet of the control valve and put handles in the bypass position (Figure 2).
- STEP 3:** Place unit at desired installation position.
- STEP 4:** Shut off water at main supply. Relieve pressure by opening nearest faucet. On private well systems, turn off power to pump and drain pressure tank. SHUT OFF POWER OR FUEL SUPPLY TO WATER HEATER.
- STEP 5:** Cut main supply line as required to fit plumbing to inlet and outlet of bypass valve. DO NOT PLUMB INLET AND OUTLET BACKWARDS. Piping should be supported. Do not apply heat to any fitting attached to the bypass or control valve.
- STEP 6:** Use the provided polyethylene tubing (**NO VINYL TUBING**) to run drain line from control valve drain fitting (Figure 2) to floor drain or sump pit capable of handling the backwash rate of the softener (refer to specifications on Page 12 - 13). **THE DISCHARGE END OF THE DRAIN LINE MUST BE FIRMLY SECURED!** There must be an air gap at the end of the drain line to prevent siphoning of wastewater and meet plumbing code. Total length of drain line should be 15' or less. AVOID OVERHEAD DRAINS.

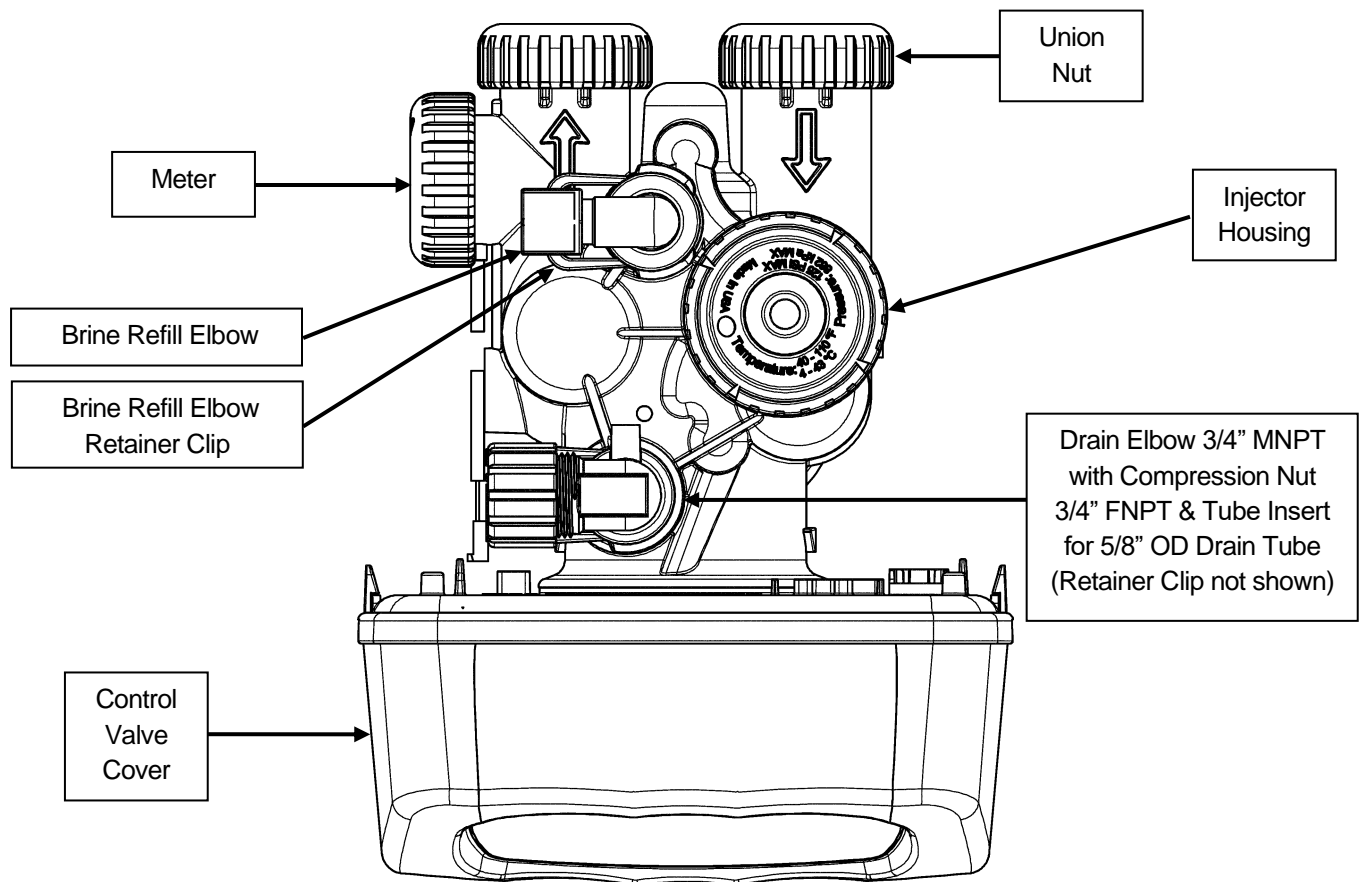

**FIGURE 2: Top View of Control Valve**

## Detailed Installation Instructions (continued)

- STEP 7:** Connect one end of the 3/8" brine line to the control valve quick connect brine refill elbow (Figure 2, Page 5). Insert the other end of the brine line through the hole in the brine tank and into the quick connect fitting on the top of the safety brine valve (Figure 3). Remove the quick connect collet retainer clip (if included) before inserting the brine line into each fitting, press the tube in very firmly and replace the retainer clip behind the collet. **NOTE: THE BRINE TUBING SHOULD BE INSERTED 5/8" INTO THE FITTING. DO NOT PUT SALT INTO THE BRINE TANK AT THIS TIME.**

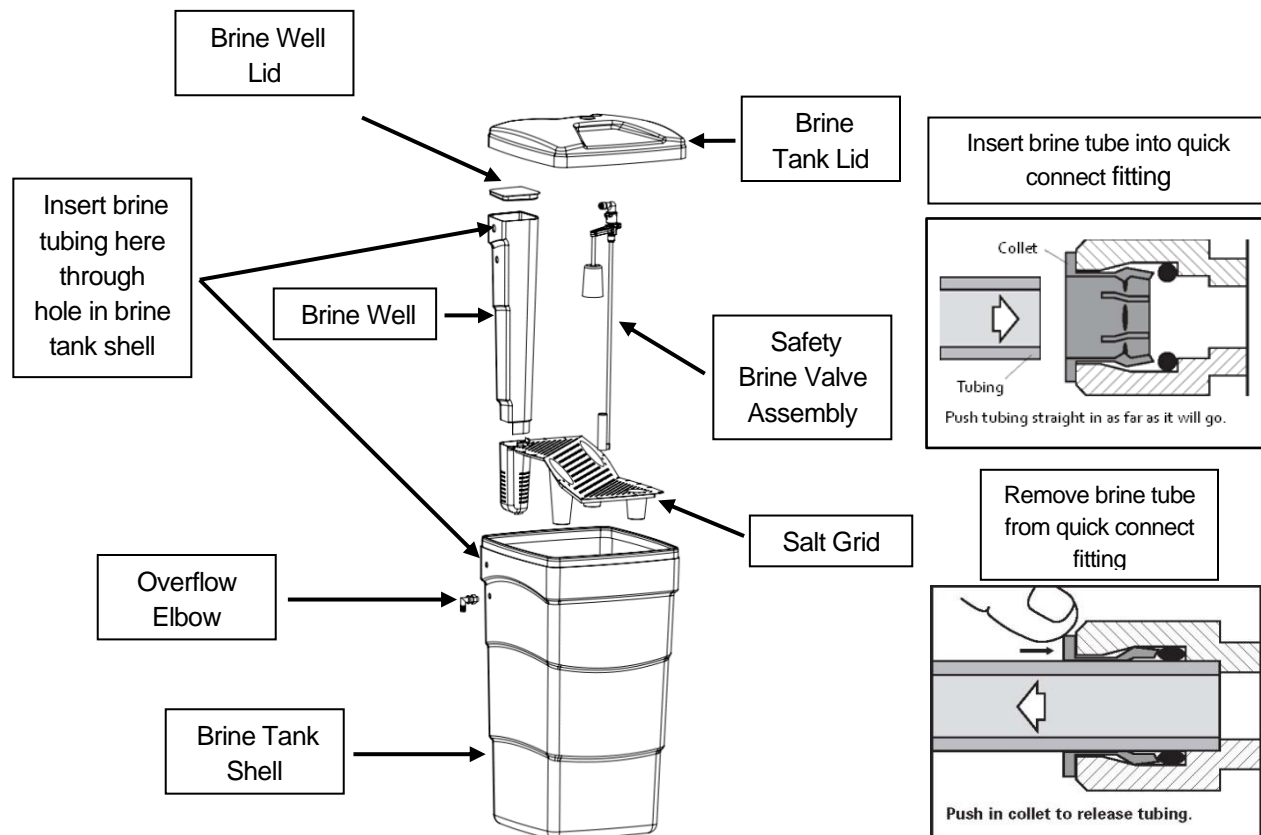

**FIGURE 3: Brine Tank Components**

- STEP 8:** If desired, install overflow tubing (not provided) from overflow elbow on brine tank (Figure 3) to floor drain. Tubing must be lower than the overflow elbow at all times. **DO NOT CONNECT DRAIN LINE FROM SOFTENER CONTROL VALVE TO BRINE TANK OVERFLOW. DO NOT CONNECT BRINE TANK DRAIN LINE TO THE SOFTENER DRAIN LINE.**
- STEP 9:** Plug the transformer into an un-switched electrical outlet. Ensure the control valve is in "Service" mode (display will alternate between time, gallons remaining, days remaining and flow rate).
- STEP 10:** Place the bypass valve in the "Service" position (refer to Figure 4a, Page 8) and open main supply valve or turn on power to pump on private well systems. Allow the unit to fill with water and pressurize, then place the bypass valve in the "Bypass" position.
- STEP 11:** Add water in the brine tank to slightly above the top level of the salt grid (approx. 5 - 6 gallons for units without a salt grid). **DO NOT ADD SALT TO THE BRINE TANK AT THIS TIME.**

## Detailed Installation Instructions (continued)

- STEP 12:** With the bypass valve in the “Bypass” position (refer to Figure 4a, Page 8), press and hold the REGEN button until the motor starts. Then use the REGEN button to advance the control valve to the BACKWASH cycle to release pressure and purge air from the mineral tank.
- STEP 13:** Refer to Figure 4, Page 8 for bypass valve operation. Rotate the INLET knob of the bypass valve slowly to the “Service” position (Figure 4a). If any air spurts or any softener resin is expelled to the drain, stop turning the knob until only water flows to the drain, then continue turning the knob fully to the “Service” position.
- STEP 14:** When all air has been purged from the system and only water is running to the drain, turn the OUTLET knob of the bypass valve to the “Service” position also. Allow the system to backwash for a few minutes or until the drain water runs clear.
- STEP 15:** Using the REGEN button, advance the control valve to the REGENERANT DRAW DN (downflow brine draw) cycle. Verify that the water level in the brine tank is slowly dropping (less than ½ gpm). Allow water level to drop below the top of the salt grid before continuing. If the water level does not drop, refer to page 21 for Troubleshooting. After verifying water level is dropping, use the REGEN button to advance past the BACKWASH 2, RINSE AND 5 second FILL cycle to the normal service display.
- ADD SALT TO BRINE TANK NOW.** Any type of water softener salt may be used.
- STEP 16:** Check for leaks and correct as necessary.
- STEP 17:** Turn power or fuel supply back on to water heater.
- STEP 18:** Press and hold the NEXT and UP buttons together until the screen changes to input the adjusted hardness level water (refer to Installer Settings, Page 10, for details), then press NEXT repeatedly until the time of day is displayed.
- STEP 19:** Press the CLOCK button to set the current time of day. (Page 10, note AM and PM).



# Bypass Valve

The bypass valve is used to isolate the control valve from the plumbing system's water pressure in order to perform control valve repairs or maintenance. The 1" full flow bypass valve incorporates four positions including a diagnostic position that allows a service technician to have pressure to test a system while providing untreated bypass water to the building. Be sure to install bypass valve onto main control valve, before beginning plumbing or make provisions in the plumbing system for a bypass. The bypass body and rotors are glass filled Noryl® and the nuts and caps are glass filled polypropylene. All seals are self-lubricating EPDM to help prevent valve seizing after long periods of non-use. Internal "O" Rings can easily be replaced if service is required. The bypass consists of two interchangeable plug valves that are operated independently by red arrow shaped handles. The handles identify the direction of flow. The plug valves enable the bypass valve to operate in four positions.

1. **Normal Operation Position:** The inlet and outlet handles point in the direction of flow indicated by the engraved arrows on the control valve. Water flows through the control valve for normal operation of a water softener or filter. During the regeneration cycle this position provides regeneration water to the unit, while also providing untreated water to the distribution system (**Fig. 4a**).
2. **Bypass Position:** The inlet and outlet handles point to the center of the bypass. The system is isolated from the water pressure in the plumbing system. Untreated water is supplied to the building (**Fig. 4b**).
3. **Diagnostic Position:** The inlet handle points toward the control valve and the outlet handle points to the center of bypass valve. Untreated supply water is allowed to flow to the system and to the building, while not allowing water to exit from the system to the building (**Fig. 4c**). This allows the service technician to draw brine and perform other tests without the test water going to the building.

**NOTE:** The system must be run through a rinse cycle before returning the bypass valve to the normal position.

4. **Shut Off Position:** The inlet handle points to the center of the bypass valve and the outlet handle points away from the control valve. The water is shut off to the building. The water treatment system will depressurize upon opening a tap in the building. A negative pressure in the building combined with the softener being in regeneration could cause a siphoning of brine into the building. If water is available on the outlet side of the softener it is an indication of water bypassing the system (**Fig. 4d**)

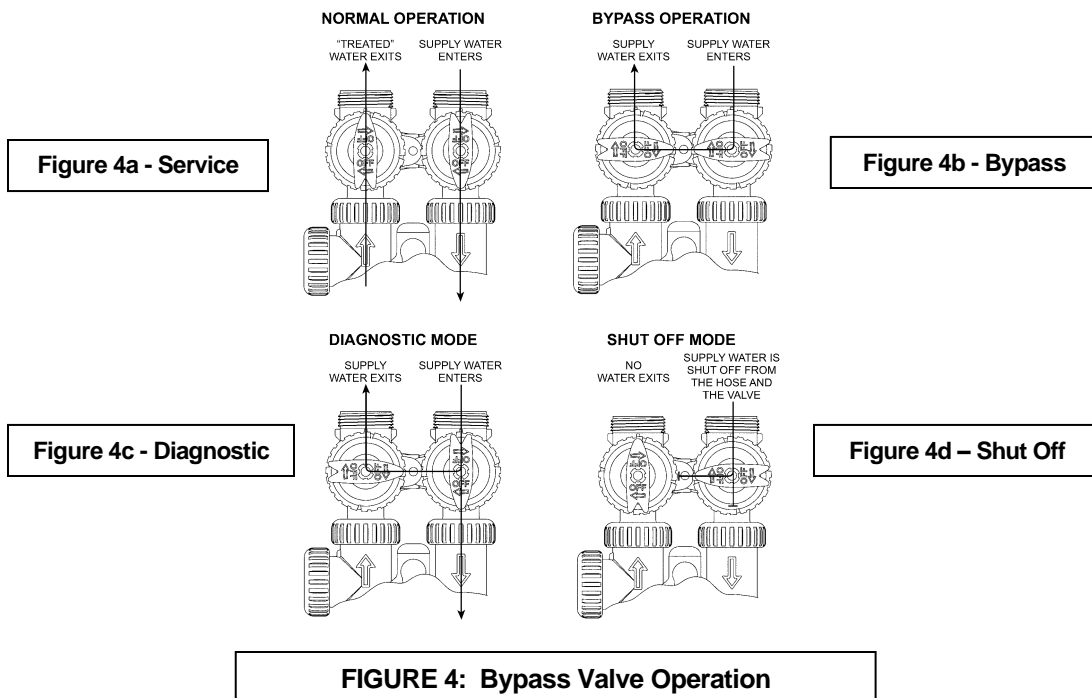

# General Operation

## USER DISPLAYS

When the system is operating, one of several displays may be shown. Pressing NEXT will alternate between the displays. One of the displays is the current time of day. The second display shows days to a regen/gallons remaining. Days To A Regen is the number of days left before the system goes through a regeneration cycle. Capacity remaining is the number of gallons that will be treated before the system goes through a regeneration cycle. The third display is current flow in gal/min. The user can scroll between the displays as desired by pushing NEXT or display will scroll automatically. When water is being treated (i.e. water is flowing through the system) the word "GPM" flashes on left side of display when other than flow rate is displayed. User screens will continuously scroll, switching views every 3 seconds. If the screens are manually scrolled, this screen will remain constant for 5 minutes then continue to scroll. The conditional screens will take precedence over the scrolling and the conditional conditions will apply. To manually reduce capacity, press down button while capacity remaining or days to a regen is displayed.

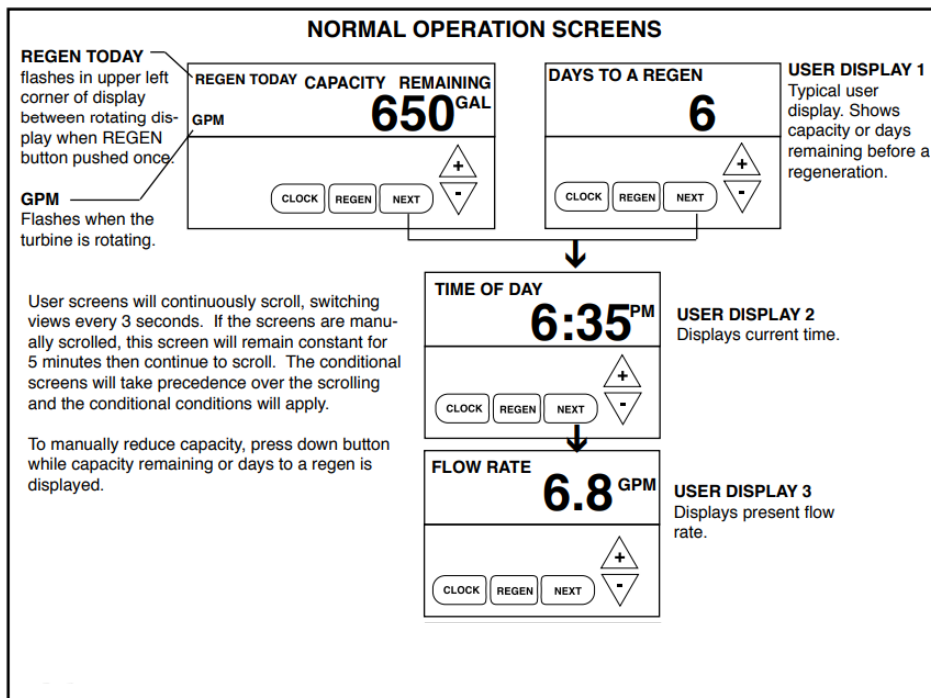

## MANUAL REGENERATION

Sometimes there is a need to regenerate the system sooner than when the system calls for it, usually referred to as manual regeneration. There may be a period of heavy water usage because of guests or a heavy laundry day. To initiate a manual regeneration at the preset delayed regeneration time, press and release "REGEN". The words "REGEN TODAY" will flash in left corner of display as it scrolls through displays to indicate that the system will regenerate at the preset delayed regeneration time. If you pressed the "REGEN" button in error, pressing the button again will cancel the request. To initiate a manual regeneration immediately, press and hold the "REGEN" button for five seconds. The system will begin to regenerate immediately. The request cannot be cancelled. You must cycle all the way through the cycles to make it stop. PLEASE NOTE: This will reset the meter. Note: If the salt tank does not contain salt, fill with salt and wait at least two hours before regenerating. If two regenerations are desired within 24 hour period, press /release REGEN button. REGEN TODAY will flash on screen. Press and hold REGEN button until valve initiates an immediate regeneration.

# Installer Settings

## A) SET THE TIME OF DAY

1. Press the "CLOCK" button
  - a. The upper left of the display will show "TIME HOUR"
  - b. The lower left of the display will show "SET"
  - c. The hour and AM or PM will flash
2. Press the UP or DOWN buttons (triangle pointing up or down) until the correct combination of hour and "AM" or "PM" is reached to match the current time.
3. Press the "NEXT" button
  - a. The upper left of the display will show "TIME MINUTES"
  - b. The lower left of the display will show "SET"
  - c. The minutes will flash
4. Press the UP or DOWN buttons until the minutes match the current time. If you need to go back to the HOUR screen press the "REGEN" button.
5. Press the "NEXT" button to return to the main screen.

**Power Loss** - Lithium battery on circuit board provides up to 2 years of time clock backup during power outages. If the power is out when battery is depleted, only time of day needs to be reset, all other values are stored in non-volatile memory. When time of day is flashing, replace lithium coin type 2032 battery. Battery back-up feature will be activated after 24 hours of power.

**B) Enter Programming:** The manufacturer has preset the unit so gallons between regenerations are automatically calculated after hardness is entered.

1. **Hardness:** Press "NEXT" and UP (triangle pointing up) buttons simultaneously for 3 seconds.
  - a. The upper left of the display will show "WATER HARDNESS"
  - b. The lower left of the display will show "SET"
  - c. A number will flash (default 20) followed by "GR" (grains).
2. Based on water analysis results (obtained either from a lab or in-field testing). Set the amount of hardness in grains per gallon using the UP or DOWN (triangle pointing up or down) buttons. The allowable range is from 1 to 150 in 1 grain increments. **Note: Increase the grains per gallon if soluble ("clear water") iron and/or manganese is present (1 ppm iron = 3 gpg hardness and 1 ppm manganese = 5 gpg hardness).**
3. **Regeneration Days Override:** Press the "NEXT" button
  - a. The upper left of the display will show "DAYS BETWEEN REGEN"
  - b. The lower left of the display will show "SET"
  - c. A number will flash (default 14)

4. Using the UP or DOWN (triangle pointing up or down) buttons, set the maximum number of days (default 14, recommended) the softener will go without initiating regeneration even if the unit still has capacity remaining based on water usage, hardness setting and capacity setting. The allowable range is 1 to 28 and OFF. If set to OFF, the unit will only regenerate based on water usage, hardness and capacity.
5. **Regeneration Time:** Press the "NEXT" button
  - a. The upper left of the display will show "REGEN TIME HOUR"
  - b. The lower left of the display will show "SET"
  - c. The hour and AM or PM will flash
6. **Regeneration Hour:** Using the UP or DOWN buttons, set the combination of hour of day and "AM" or "PM" that the BACKWASH cycle of regeneration should occur. Please note that regeneration will actually begin with the short (less than 10 minutes) Brine Fill cycle 90 minutes prior to the time set here followed by 90 minutes (default) of inactivity to allow water in the brine tank to become saturated with salt.
7. Press the "NEXT" button
  - a. The upper left of the display will show "REGEN TIME MINUTES"
  - b. The lower left of the display will show "SET"
  - c. The minutes will flash
8. **Regeneration Minutes:** Using the UP or DOWN buttons, set the minutes portion of the time when regeneration should occur. If you need to go back to the HOUR screen press the "REGEN" Button.
9. **Energy Saver:** Using the UP or DOWN buttons, set the mode of operation for Energy Saver; OFF, ON or AUTO. Unless set to OFF the display will dim when not actively using the buttons.
10. **Exit Programming:** Press the "NEXT" button
  - a. The upper left of the display will show "TIME"
  - b. The current time of day will be shown on the right side of the display
  - c. Only the colon between the hour and minutes will be flashing

# Specifications

Description	Two Tank Models				
	PWS1-30	PWS1-45	PWS1-60	PWS1-75	PWS1-90
<b>MEDIA VOLUME</b> ft <sup>3</sup>	1.0	1.5	2.0	2.5	3.0
<b>CAPACITY, grains</b>					
@Factory Salt @ 9lb/ft <sup>3</sup>	24,000	36,000	48,000	60,000	72,000
@Max. Salt @ 15lb/ft <sup>3</sup>	30,000	45,000	60,000	75,000	90,000
<b>Operating Flow Rate, gpm</b>					
Continuous (3 gpm/ft <sup>3</sup> )	3	5	5	8	9
Service (8 gpm/ft <sup>3</sup> , <= 15 psi drop)	8	12	14	18	19
Peak (Max. 20 psi drop)	18	18	23	22	23
<b>Pressure Loss psi</b>					
@ Continuous Flow Rate	2	4	2	5	5
@ Service Flow Rate	7	11	9	14	15
@ Peak Flow Rate	19	19	20	19	20
<b>Regen. Flow Rates, gpm</b>					
Backwash & Rapid Rinse	2.2	2.7	3.2	4.2	5.3
Injector	Blue	Blue	Blue	Yellow	Orange
Brine Draw / Rinse	0.38 / 0.5	0.38 / 0.5	0.38 / 0.5	0.43 / 0.64	0.60 / 1.05
<b>Service Pipe Size, in.</b>	1" & 3/4"	1" & 3/4"	1" & 3/4"	1" & 3/4"	1" & 3/4"
<b>Factory Regeneration Settings</b>					
Brine Tank Fill (lbs of salt)	9	13.5	18	22.5	27
Softening (minutes dissolving salt)	90	90	90	90	90
Backwash (minutes)	6	7	7	8	8
Brine Draw & Rinse (minutes)	45	60	70	80	65
Backwash 2 (minutes)	1	1	1	1	1
Rapid Rinse (minutes)	5	7	6	7	7
<b>Total Water Used, gallons</b>	48	69	78	114	145
<b>Dimensions in.</b>					
Mineral Tank, diameter x height	9 x 48	10 x 54	12 x 48	13 x 54	14 x 65
Brine Tank, diameter x height	18 x 33	18 x 33	18 x 33	18 x 33	23 x 42
Overall, depth x width x height	18 x 27 x 56	18 x 28 x 62	18 x 30 x 56	18 x 31 x 62	23 x 37 x 76
<b>Approximate Ship Wt., lbs.</b>	104	137	162	213	284

Description	Space Saver Model	Cabinet Models	
	PWS1C30	PWS1CC30	PWS1CC40
<b>Resin Volume, cu. ft.</b>	1.0	1.0	1.3
<b>Capacity, grains</b>			
@Factory Salt @ 9lb/ft <sup>3</sup>	24,000	24,000	32,000
@Max. Salt @ 15lb/ft <sup>3</sup>	30,000	30,000	39,000
<b>Gravel Underbed, lbs.</b>	20	20	20
<b>Operating Flow Rate, gpm</b>			
Continuous (3 gpm/ft <sup>3</sup> )	3	3	4
Service (8 gpm/ft <sup>3</sup> , <= 15 psi drop)	8	8	10
Peak (Max. 20 psi drop)	22	22	19
<b>Pressure Loss psi (kPa)</b>			
@ Continuous Flow Rate	2	2	1
@ Service Flow Rate	5	5	3
@ Peak Flow Rate	20	20	19
<b>Regen. Flow Rates, gpm</b>			
Backwash & Rapid Rinse	2.7	2.7	2.7
Injector	Blue	Blue	Blue
Brine Draw and Rinse	0.38 / 0.5	0.38 / 0.5	0.38 / 0.5
<b>Service Pipe Size, in.</b>	1" & 3/4"	1" & 3/4"	1" & 3/4"
<b>Factory Regeneration Settings</b>			
Brine Tank Fill (lbs of salt)	9	9	12
Softening (minutes dissolving salt)	90	90	90
Backwash (minutes)	5	5	6
Brine Draw & Rinse (minutes)	45	45	55
Backwash 2 (minutes)	1	1	1
Rapid Rinse (minutes)	4	4	6
<b>Total Water Used, gallons</b>	48	48	61
<b>Dimensions in.</b>			
Mineral Tank, diameter x height	10 x 35	10 x 35	10 x 44
Brine Tank, w x d x h	12 x 12 x 34	-NA-	-NA-
Overall, length x width x height	16 x 23 x 43	12 x 24 x 45	12 x 24 x 50
<b>Approximate Ship Wt., lbs.</b>	94	105	135

# Specifications (cont.)

Description	High Efficiency Model Numbers					
	PWS1C30-HE (Space Saver)	PWS1-30-HE	PWS1-45-HE	PWS1-60-HE	PWS1-75-HE	PWS1-90-HE
<b>Media Volume, ft<sup>3</sup></b>	1.0	1.0	1.5	2.0	2.5	3.0
<b>Capacity, grains</b>						
@ Factory Salt – 6lb/ft <sup>3</sup>	22,000	22,000	33,000	44,000	55,000	66,000
@ Max. Salt – 15lb/ft <sup>3</sup>	31,000	31,000	46,500	62,000	93,000	93,000
<b>Operating Flow Rate, gpm</b>						
Continuous (3 gpm / ft <sup>3</sup> )	3	3	5	5	8	9
Service (8 gpm / ft <sup>3</sup> , <=15 psi drop)	8	8	12	14	18	19
Peak (Max. 20 psi drop)	22	18	18	23	22	23
<b>Pressure Loss psi</b>						
@ Continuous Flow Rate	2	2	4	2	5	5
@ Service Flow Rate	5	7	11	9	14	15
@ Peak Flow Rate	20	19	19	20	19	20
<b>Regen. Flow Rates, gpm</b>						
Backwash & Rapid Rinse	2.7	2.2	2.7	3.2	4.2	5.3
Injector	Blue	Blue	Blue	Blue	Yellow	Orange
Brine Draw and Rinse	0.38 / 0.5	0.38 / 0.5	0.38 / 0.5	0.38 / 0.5	0.43 / 0.64	0.60 / 1.05
<b>Service Pipe Size, in.</b>	1" & 3/4"	1" & 3/4"	1" & 3/4"	1" & 3/4"	1" & 3/4"	1" & 3/4"
<b>Factory Regeneration Settings</b>						
Brine Tank Fill (lbs of salt)	6	6	9	12	15	18
Softening (minutes dissolving salt)	90	90	90	90	90	90
Backwash (minutes)	4	5	6	6	7	7
Brine Draw & Rinse (minutes)	35	40	55	60	70	55
Backwash 2 (minutes)	1	1	1	1	1	1
Rapid Rinse (minutes)	4	4	5	5	5	5
<b>Total Water Used, gallons</b>	41	41	59	67	97	122
<b>Dimensions in.</b>						
Mineral Tank, diameter x height	10 x 35	9 x 48	10 x 54	12 x 48	13 x 54	14 x 65
Brine Tank, diameter x height	12 x 12 x 34	18 x 33	18 x 33	18 x 33	18 x 33	23 x 42
Overall, length x width x height	16 x 23 x 43	18 x 27 x 56	18 x 28 x 62	18 x 30 x 56	18 x 31 x 62	23 x 37 x 76
<b>Approximate Ship Wt., lbs.</b>	94	104	137	162	213	213

# Component Parts Breakdown

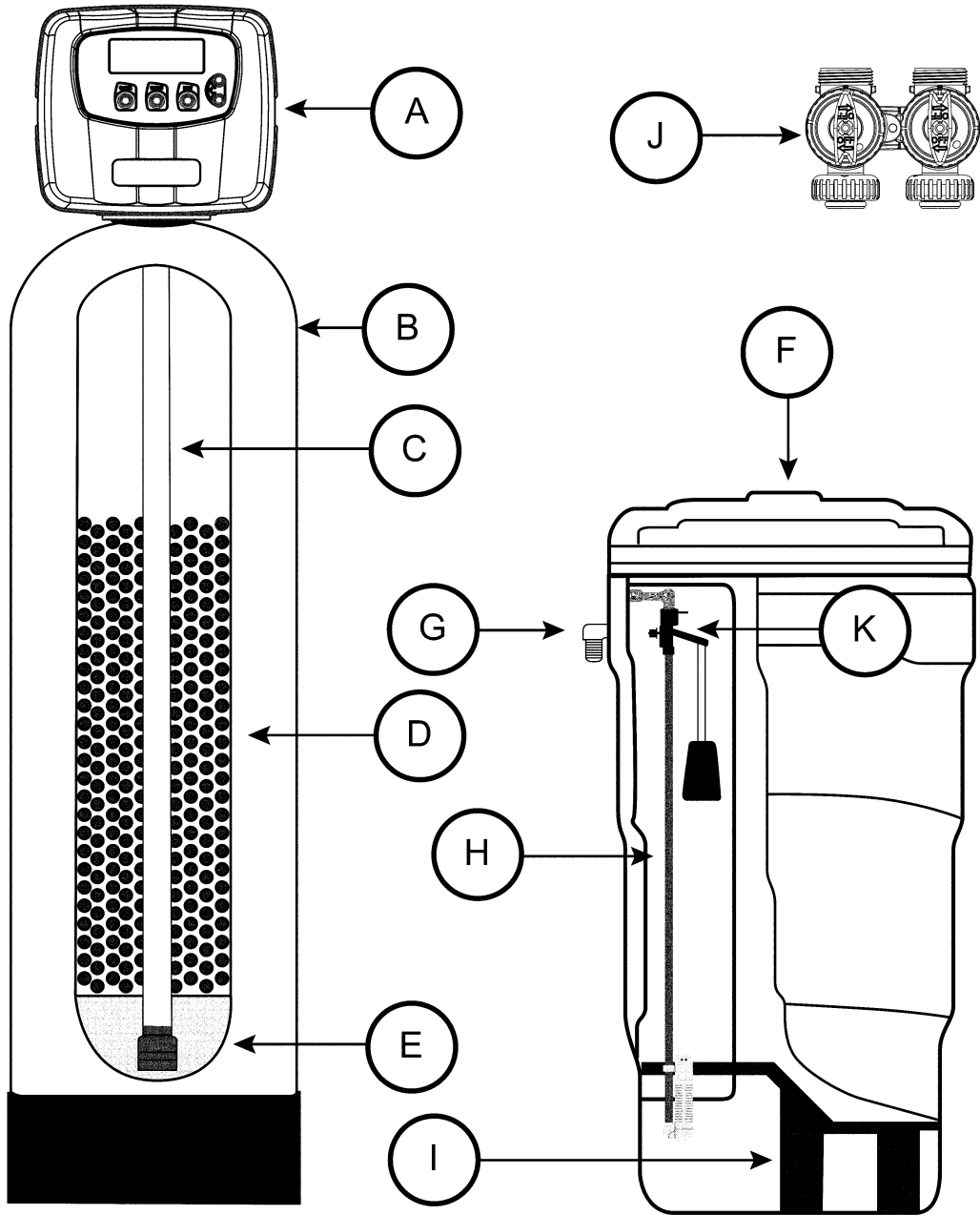

# Component Parts List

REF	DESCRIPTION	MODEL NUMBER				
		PWS1-30	PWS1-45	PWS1-60	PWS1-75	PWS1-90
A*	Control Valve	PWS1-30-VLV-L-BP-	PWS1-45-VLV-L-BP-	PWS1-60-VLV-L-BP-	PWS1-75-VLV-L-BP-	PWS1-90-VLV-L-BP-
B	Mineral Tank	MTP0948GR	MTP1054GR	MTP1248GR	MTP1354N	MTP1465N
C	Distributor	D100S-48	D100S-54	D100S-48	D100S-54	D100S-65
D	Resin	2 - H05P	3 - H05P	4 - H05P	5 - H05P	6 - H05P
E	1/4" x 1/8" gravel	QC20	QC20	QC20	2 - QC20	QC50
F	Brine Tank Assy.	BTSQ1833ASSY	BTSQ1833ASSY	BTSQ1833ASSY	BTSQ1833ASSY	BT2342ASSY
G	Overflow Elbow	BT-OVERFLO	BT-OVERFLO	BT-OVERFLO	BT-OVERFLO	BT-OVERFLO
H	Safety Brine Valve	SBV14ASSY	SBV14ASSY	SBV14ASSY	SBV14ASSY	SBV23ASSY
I	Salt Platform	BTSG18SQ	BTSG18SQ	BTSG18SQ	BTSG18SQ	BTSG23
J**	Bypass Valve Less Fittings	CV3006	CV3006	CV3006	CV3006	CV3006
K	Elbow Locking Clip	FC103	FC103	FC103	FC103	FC103

REF	DESCRIPTION	MODEL NUMBER		
		PWS1C30	PWS1CC30	PWS1CC40
A*	Control Valve	PWS1C30-VLV-L-BP-	PWS1CC30-VLV-L-BP-	PWS1CC40-VLV-L-BP-
B	Mineral Tank	MTP1035GR	MTP1035GR	MTP1044GR
C	Distributor	D100S-48	D100S-48	D100S-48
D	Resin	2 - H05P	2 - H05P	2.5 - H05P
E	1/4" x 1/8" gravel	QC20	QC20	QC20
F	Brine Tank Assy.	BT1234ASSY	BC-1035C	BC-1044C
G	Overflow Elbow	BT-OVERFLO	BT-OVERFLO	BT-OVERFLO
H	Safety Brine Valve	SBV14ASSY	SBV14ASSY	SBV14ASSY
I	Salt Platform	BTSG12	--NA--	--NA--
J**	Bypass Valve Less Fittings	CV3006	CV3006	CV3006
K	Elbow Locking Clip	FC103	FC103	FC103

REF	DESCRIPTION	MODEL NUMBER					
		PWS1C30-HE (Space Saver)	PWS1-30-HE	PWS1-45-HE	PWS1-60-HE	PWS1-75-HE	PWS1-90-HE
A*	Control Valve	PWS1C30-HE-VLV-L-BP-	PWS1-30-HE-VLV-L-BP-	PWS1-45-HE-VLV-L-BP-	PWS1-60-HE-VLV-L-BP-	PWS1-75-HE-VLV-L-BP-	PWS1-90-HE-VLV-L-BP-
B	Mineral Tank	MTP1035GR	MTP0948GR	MTP1054GR	MTP1248GR	MTP1354N	MTP1465N
C	Distributor	D100S-48	D100S-48	D100S-54	D100S-48	D100S-54	D100S-65
D	Resin	2 - UHE05P	2 - UHE05P	3 - UHE05P	4 - UHE05P	5 - UHE05P	6 - UHE05P
E	1/4" x 1/8" gravel	QC20	QC20	QC20	QC20	2 - QC20	QC50
F	Brine Tank Assy.	BT1234ASSY	BTSQ1833ASSY	BTSQ1833ASSY	BTSQ1833ASSY	BTSQ1833ASSY	BT2342ASSY
G	Overflow Elbow	BT-OVERFLO	BT-OVERFLO	BT-OVERFLO	BT-OVERFLO	BT-OVERFLO	BT-OVERFLO
H	Safety Brine Valve	SBV14ASSY	SBV14ASSY	SBV14ASSY	SBV14ASSY	SBV14ASSY	SBV23ASSY
I	Salt Platform	BTSG12	BTSG18	BTSG18	BTSG18	BTSG18	BTSG23
J**	Bypass Valve Less Fittings	CV3006	CV3006	CV3006	CV3006	CV3006	CV3006
K	Elbow Locking Clip	FC103	FC103	FC103	FC103	FC103	FC103

\*A top screen (18280-02, not shown) is included with the control valve assembly of "-HE" suffix, Cabinet & Space Saver models  
 \*\*Refer to "Installation Fitting Assemblies" pages 18-19 for available I/O fittings.

**ALL MODELS INCLUDE 3/4" QUICK CONNECT FITTINGS AS WELL AS 1" MALE NPT ELBOWS**



# Control Valve Breakdown

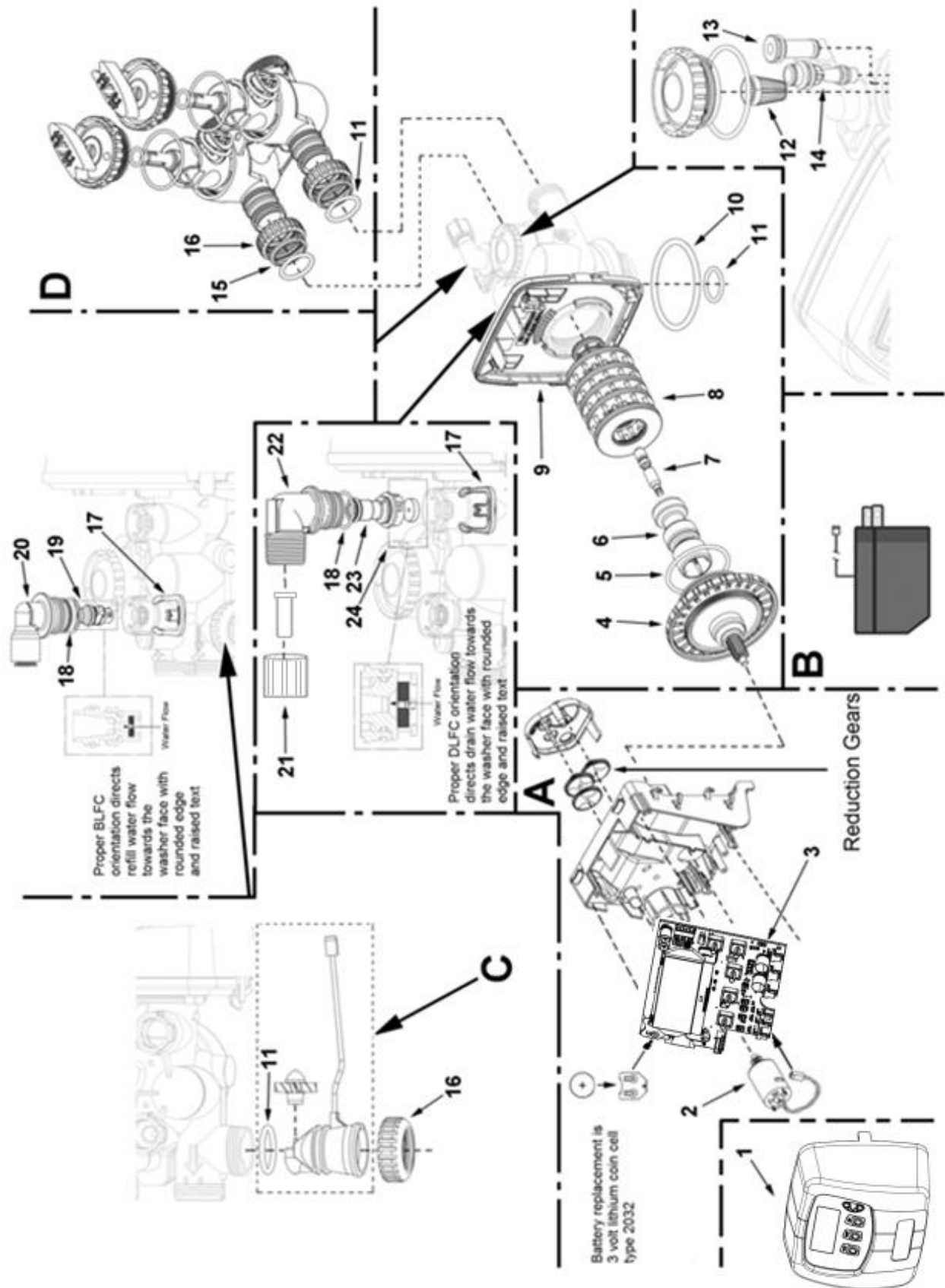

# Control Valve Parts List

REF #	Part Number	Description
A	CV3002-A	Drive Assembly (does not include circuit board or motor)
B	CV3186-06	Power Cord with Transformer, 15 VDC
C	CV3003	Meter and Cable Assembly
D	CV3006	Bypass Valve, Less Fittings
1	CV3998-01FA	Front Cover, PXX1 Series
2	CV3107-01	Drive Motor
3	CV3578HP-02BOARD	Circuit Board, PXX1 Series
4	CV3004	Drive Cap Assembly
5	CV3135	O-ring, -228
6	CV3011	Piston Assembly
7	CV3174	Brine Valve
8	CV3005	Seal Cartridge Assembly
9	CV3946	Back Plate, PXX1 Series
10	CV3180	Base O-ring, -337
11	CV3105	O-ring, -215
12	CV3177-01	Injector Screen
13	CV3010-1Z	Plug, Injector Assembly
14	CV3010-1F CV3010-1G CV3010-1I	Injector, Dark Blue (all models other than those below) Injector, Yellow (PWS1-75, PWS1-75-HE) Injector, Orange (PWS1-90, PWS1-90-HE)
15	CV3150	Retainer, Split Ring
16	CV3151	Nut, 1" Quick Connect
17	CH4615	Clip, Elbow Locking
18	CV3163	O-ring, -019
19	CV3165-01	Retainer, Brine Refill Flow Control
20	CV4144	3/8" Elbow, Parker fitting
21	CV3192 PKP10TS8BULK	Compression nut, 3/4" FNPT, for drain elbow Insert, for 5/8" OD poly tube
22	CV3158-02	Elbow, Drain, 3/4" Male
23	CV3159-01	Retainer, Drain Line Flow Control
24	CV3162-022 CV3162-027 CV3162-032 CV3162-042 CV3162-053	<b>Drain Line Flow Control Button:</b> Flow Control Washer, 2.2 GPM (09x48 tanks) Flow Control Washer, 2.7 GPM (10x35, 10x44, 10x54 tanks) Flow Control Washer, 3.2 GPM (12x48 tanks) Flow Control Washer, 4.2 GPM (13x54 tanks) Flow Control Washer, 5.3 GPM (14x65 tanks)

# Installation Fitting Assemblies

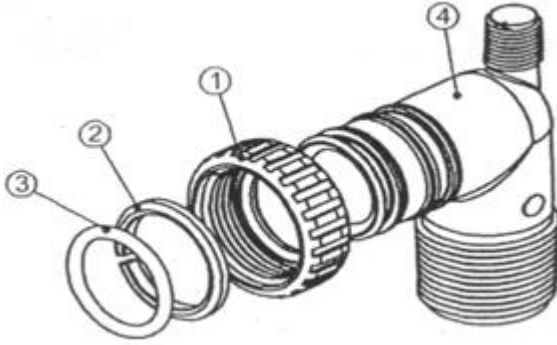

1" PVC MALE NPT ELBOW			
Ref	Part #	Description	Qty
	CV3007	1" PVC male NPT elbow assy	2
1	CV3151	Nut, 1" quick connect	2
2	CV3150	Split ring	2
3	CV3105	O-ring 215	2
4	CV3149	Fitting	2

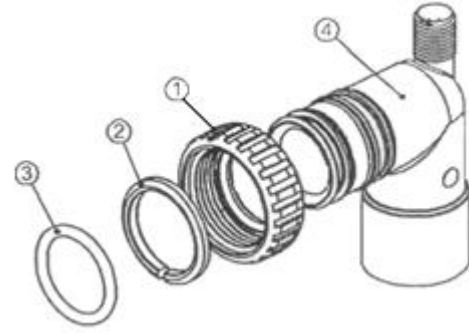

3/4" & 1" PVC SOLVENT ELBOW			
Ref	Part #	Description	Qty
	CV3007-01	3/4" & 1" PVC solvent elbow assy	2
1	CV3151	Nut, 1" quick connect	2
2	CV3150	Split ring	2
3	CV3105	O-ring 215	2
4	CV3189	Fitting	2

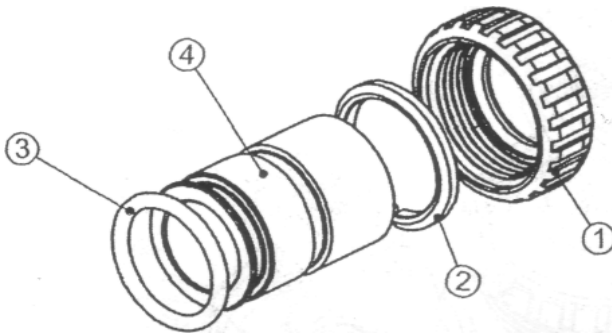

1" BRASS SWEAT			
Ref	Part #	Description	Qty
	CV3007-02	1" brass sweat assembly	2
1	CV3151	Nut, 1" quick connect	2
2	CV3150	Split ring	2
3	CV3105	O-ring 215	2
4	CV3188	Fitting	2

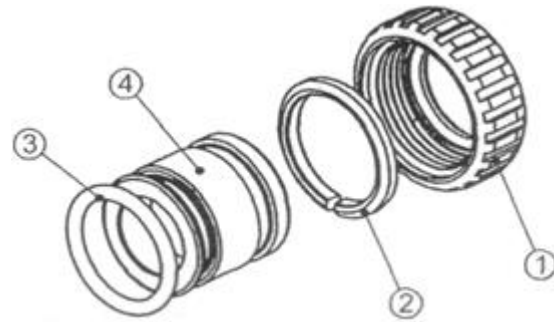

3/4" BRASS SWEAT			
Ref	Part #	Description	Qty
	CV3007-03	3/4" brass sweat assembly	2
1	CV3151	Nut, 1" quick connect	2
2	CV3150	Split ring	2
3	CV3105	O-ring 215	2
4	CV3188-01	Fitting	2

## Installation Fitting Assemblies (cont.)

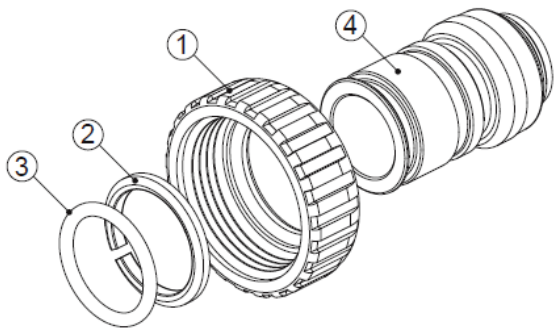

3/4" BRASS SHARK BITE			
Ref	Part #	Description	Qty
	CV3007-12	3/4" brass shark bite assembly	2
1	CV3151	Nut, 1" quick connect	2
2	CV3150	Split ring	2
3	CV3105	O-ring 215	2
4	CV3628	Fitting	2

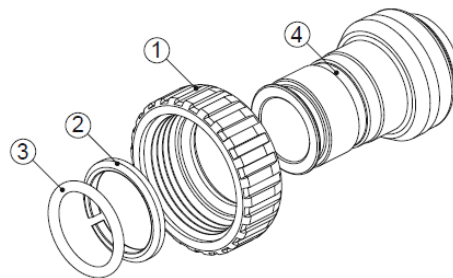

1" BRASS SHARK BITE			
Ref	Part #	Description	Qty
	CV3007-13	1" brass shark bite assembly	2
1	CV3151	Nut, 1" quick connect	2
2	CV3150	Split ring	2
3	CV3105	O-ring 215	2
4	CV3629	Fitting	2

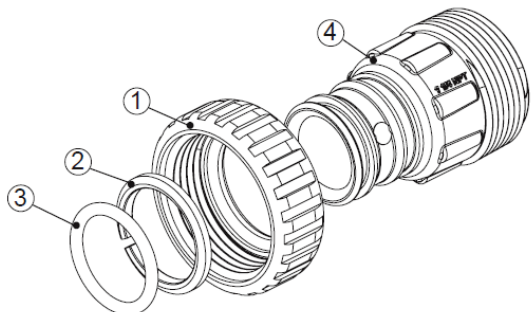

1-1/4" PLASTIC MALE NPT			
Ref	Part #	Description	Qty
	CV3007-05	1-1/4" plastic male NPT assembly	2
1	CV3151	Nut, 1" quick connect	2
2	CV3150	Split ring	2
3	CV3105	O-ring 215	2
4	CV3317	Fitting	2

## Installation Fitting Assemblies (cont.)



3/4" QUICK CONNECT			
Ref	Part #	Description	Qty
K	QFNCR4	3/4" QUICK CONNECT	1*

(\*2 required)

Loosens Drain Nut In  
Polytube Applications

Loosens Injector and  
Bypass Caps

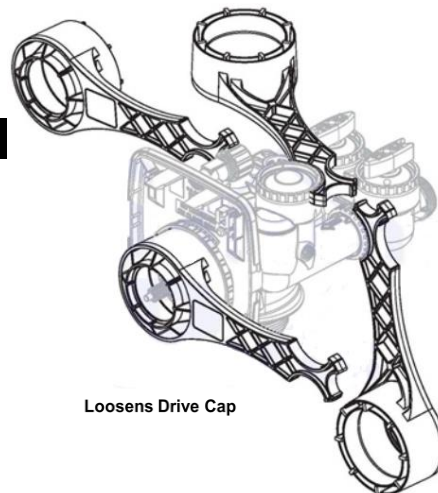

Loosens Quick  
Connect Nuts

Loosens Drive Cap

### SERVICE WRENCH - CV3193

Although no tools are necessary to assemble or disassemble the valve, the *Service Wrench*, (shown in various positions on the valve) is available to aid in assembly or disassembly.

# Troubleshooting

PROBLEM	CAUSES	SOLUTIONS
Brine tank overfills or does not draw brine	<ul style="list-style-type: none"> <li>A) Brine line not fully inserted into fittings</li> <li>B) Brine line inserted into the brine tank overflow fitting rather than connected to the safety brine valve</li> <li>C) Softener drain line connected to brine overflow fitting or overflow drain line</li> <li>D) Obstruction in the control valve</li> <li>E) Problems with drain line: plugged, frozen, kinked, flexible tubing, overhead installation, diameter too small, longer than 15'</li> <li>F) Missing BLFC</li> <li>G) Missing brine stem</li> <li>H) Worn seals</li> </ul>	<ul style="list-style-type: none"> <li>1) Tighten nuts at either end of brine line</li> <li>2) Verify brine line is installed correctly</li> <li>3) Verify softener drain line is not connected to brine overflow elbow or brine overflow drain line</li> <li>4) Check for debris in DLFC Assembly, BLFC Assembly, injector, injector screen</li> <li>5) Manually put softener into Backwash Cycle (page 9) and unplug the transformer for 30 minutes to dislodge debris from inside the control valve or disassemble and clean control valve internal components</li> <li>6) Resolve issues with the drain line</li> <li>7) Verify brine line flow control button is not missing</li> <li>8) Verify piston brine stem is not missing</li> <li>9) Replace seal and spacer assembly</li> </ul>
Hard water or softener not using salt	<ul style="list-style-type: none"> <li>A) Softener is plugged into an electrical outlet without power or one that is tied to a switch</li> <li>B) No salt in the brine tank</li> <li>C) Salt in the brine tank has "bridged"</li> <li>D) Bypass Valve is not in "Service" position or is leaking</li> <li>E) Obstruction in control valve</li> <li>I) Problems with drain line: : (See letter "E" in prior section)</li> <li>F) Control valve programmed incorrectly</li> <li>G) Softener sized improperly for actual service flow rates</li> <li>H) Faulty or unplugged drive motor</li> <li>I) Meter cable disconnected</li> </ul>	<ul style="list-style-type: none"> <li>1) Verify softener has uninterrupted power</li> <li>2) Fill brine tank with salt</li> <li>3) Hit the side of the brine tank with rubber mallet to break any bridging that has formed in the brine tank</li> <li>4) Verify bypass is in "Service" position (Figure 4a, Page 8)</li> <li>5) Check for debris in DLFC Assembly, BLFC Assembly, injector, injector screen</li> <li>6) Manually put softener into Backwash Cycle (page 9) and unplug transformer for 20-30 minutes to dislodge debris</li> <li>7) Resolve issues with drain line</li> <li>8) Review control valve programming</li> <li>9) Verify actual service flow rates required and compare to system specifications (pages 12-13)</li> <li>10) Verify drive motor is connected to control valve circuit board connector J1 (labeled "MOTOR")</li> <li>11) Verify meter cable (grey cable, 3 pins) is connected to control valve circuit board connector J2 (labeled "METER")</li> </ul>

## Troubleshooting (cont.)

PROBLEM	CAUSES	SOLUTIONS
Softener regenerates at wrong time of day	<ul style="list-style-type: none"> <li>A) Clock is not set</li> <li>B) Power outage</li> <li>C) Incorrect control valve programming</li> </ul>	<ul style="list-style-type: none"> <li>1) Reset softener clock (pages 9 &amp; 10)</li> <li>2) Verify control valve programming (pages 10 - 11)</li> </ul>
Resin in water lines, plugged aerators	<ul style="list-style-type: none"> <li>A) Unit is installed backwards</li> <li>B) Distributor basket is damaged</li> </ul>	<ul style="list-style-type: none"> <li>1) Re-plumb unit with water supply entering bypass inlet (page 5)</li> <li>2) Replace damaged distributor basket</li> </ul>
Salty Water	<ul style="list-style-type: none"> <li>A) Brine tank overfilled</li> <li>B) Problems with drain line: (See Letter "E" in Brine Tank Overfill section)</li> <li>C) Rinse cycle is short</li> <li>D) Salt setting too high</li> <li>E) Distributor tube improperly seated in control valve or is too short</li> <li>F) Low water pressure</li> </ul>	<ul style="list-style-type: none"> <li>1) See "Brine tank overfills" section (Page 21)</li> <li>2) Resolve drain line issues</li> <li>3) Contact technical support for assistance in verifying \ adjusting Rinse Cycle length and Salt Setting</li> <li>4) Verify proper installation of distributor tube</li> <li>5) Verify at least 25 psi of line pressure</li> </ul>
Softener leaks to drain in "Service" position	<ul style="list-style-type: none"> <li>A) Problem in piston cartridge assembly</li> <li>B) Control valve is jammed or halted during regeneration</li> <li>C) Drive cap assembly is not tightened properly</li> </ul>	<ul style="list-style-type: none"> <li>1) Replace seals and/or piston if needed</li> <li>2) Verify control valve is in "SOFTENING" mode</li> <li>3) Tighten drive cap assembly</li> </ul>
Low water pressure	<ul style="list-style-type: none"> <li>A) Iron or sediment build up in softener</li> <li>B) Insufficient pump capacity</li> </ul>	<ul style="list-style-type: none"> <li>1) Increase backwash frequency by increasing hardness setting (page 10)</li> <li>2) Verify at least 25 psi of line pressure</li> </ul>
Display is blank	<ul style="list-style-type: none"> <li>A) Control valve circuit board needs reset</li> <li>B) Transformer is unpowered, unplugged or defective</li> <li>C) Defective circuit board</li> </ul>	<ul style="list-style-type: none"> <li>1) Hold "NEXT" and "REGEN" buttons for 3 seconds</li> <li>2) Remove battery, unplug power for 5 seconds, plug back in, replace dead battery</li> <li>3) Verify transformer is plugged into an electrical outlet that has power and transformer cable (black, 4 pins) is plugged into control valve connector J4 (labeled "POWER")</li> <li>4) With transformer plugged into electrical outlet, use a volt meter to test the 2 outer pins (furthest left and furthest right) of connector J4 on the control valve circuit board. Should be approximately 15 volts DC. Replace transformer if defective.</li> <li>5) Replace circuit board if needed</li> </ul>
"SOFTENING" does not display when water is flowing	<ul style="list-style-type: none"> <li>A) Bypass valve not in "Service" position</li> <li>B) Meter cable disconnected</li> <li>C) Restricted/stalled meter turbine</li> <li>D) Defective meter</li> </ul>	<ul style="list-style-type: none"> <li>1) Verify bypass is in "Service" position (Figure 4a, Page 8)</li> <li>2) Verify meter cable (grey cable, 3 pins) is connected to control valve circuit board connector J2 (labeled "METER")</li> <li>3) Remove meter and check for restriction</li> <li>4) Replace meter if needed</li> </ul>

## Troubleshooting (cont.)

PROBLEM	CAUSES	SOLUTIONS
Display shows incorrect time-of-day or time-of-day flashes	<ul style="list-style-type: none"> <li>A) Outlet is on a switch</li> <li>B) Power outage</li> <li>C) Control valve was reset</li> <li>D) Defective circuit board</li> </ul>	<ul style="list-style-type: none"> <li>1) Use an un-switched outlet</li> <li>2) Reset time-of-day</li> <li>3) Replace circuit board if needed</li> </ul>
<b>ERROR CODE:</b>		
<b>1001</b> – unable to sense motor movement	<ul style="list-style-type: none"> <li>A) Drive motor not inserted fully to engage pinion or is defective</li> <li>B) Circuit board not properly snapped into drive bracket</li> <li>C) Center reduction gear reflector dirty</li> </ul>	<ul style="list-style-type: none"> <li>1) Re-insert motor, check for broken wires, verify motor plugged into connector J1 (labeled “MOTOR”) on control valve circuit board and reset control valve (hold “NEXT” and “REGEN” buttons for 3 seconds)</li> <li>2) Re-seat circuit board into drive bracket and reset control valve</li> <li>3) Clean reduction gear reflectors (page 17)</li> </ul>
<b>1002</b> – unexpected motor stall	<ul style="list-style-type: none"> <li>A) Obstruction in control valve</li> <li>B) Main drive gear too tight</li> <li>C) Improper voltage delivered to circuit board</li> </ul>	<ul style="list-style-type: none"> <li>1) Remove piston and seal assemblies for inspection and repair or replacement and reset control valve (hold “NEXT” and “REGEN” buttons for 3 seconds)</li> <li>2) Loosen main drive gear and reset control valve</li> <li>3) Verify proper voltage is being supplied to circuit board (see Solution 4 under “Display is Blank” section, page 22)</li> </ul>
<b>1003</b> – motor ran too long, cannot find next cycle position	<ul style="list-style-type: none"> <li>A) Motor failure during regeneration</li> <li>B) Obstruction in control valve</li> <li>C) Drive bracket not snapped in place properly</li> </ul>	<ul style="list-style-type: none"> <li>1) Re-insert motor, check for broken wires, verify motor plugged into connector J1 (labeled “MOTOR”) on control valve circuit board and reset control valve (hold “NEXT” and “REGEN” buttons for 3 seconds)</li> <li>2) Remove piston and seal assemblies for inspection and repair or replacement and reset control valve</li> <li>3) Re-seat drive bracket assembly and reset control valve</li> </ul>
<b>1004</b> – motor ran too long, timed out trying to reach home position	<ul style="list-style-type: none"> <li>A) Drive bracket not snapped in place properly</li> <li>B) Center reduction gear reflector dirty</li> </ul>	<ul style="list-style-type: none"> <li>1) Re-seat drive bracket assembly and reset control valve (hold “NEXT” and “REGEN” buttons for 3 seconds)</li> <li>2) Clean reduction gear reflectors (page 16)</li> </ul>
<b>1006</b> – MAV/SEPS/NHBP/AUX MAV motor ran too long, looking for park position	<ul style="list-style-type: none"> <li>A) Control valve not programmed for ALT OFF</li> <li>B) Obstruction in control valve</li> </ul>	<ul style="list-style-type: none"> <li>1) Enter cycle programming level and verify second parameter is set to ALT OFF</li> <li>2) Remove piston and seal assemblies for inspection and repair or replacement and reset control valve (hold “NEXT” and “REGEN” buttons for 3 seconds)</li> </ul>
<b>1007</b> – MAV/SEPS/NHBP/AUX MAV motor ran too short looking for park position	<ul style="list-style-type: none"> <li>A) Control valve not programmed for ALT OFF</li> <li>B) Obstruction in control valve</li> </ul>	<ul style="list-style-type: none"> <li>1) Enter cycle programming level and verify second parameter is set to ALT OFF</li> <li>2) Remove piston and seal assemblies for inspection and repair or replacement and reset control valve (hold “NEXT” and “REGEN” buttons for 3 seconds)</li> </ul>



# TEN YEAR LIMITED WARRANTY

**WARRANTY** – Franklin Water Treatment, LLC, warrants this water conditioner against any defects that are due to faulty material or workmanship during the warranty period. This warranty does not include damage to the product resulting from accident, neglect, misuse, misapplication, alteration, installation, or operation contrary to printed instructions, or damage caused by freezing, fire, flood, or Acts of God. From the original date of consumer purchase, we will repair or replace, at our discretion, any part found to be defective within the warranty period described below. Purchaser is responsible for any shipping cost to our facility and any local labor charges.

- One year on the entire water conditioner
- Five years on the control valve  
(except the seal & spacer kit which is a wear & tear component, 1 year)
- Five years on the brine tank (if applicable)
- Ten years on the mineral tank

**GENERAL CONDITIONS** – Should a defect or malfunction occur, contact the dealer that you purchased the product from. If you are unable to contact the dealer, contact Franklin Water Treatment, LLC at (260)693-1972. We will require a full description of the problem, model number, date of purchase, and selling dealer’s business name and address.

We assume no warranty liability in connection with this water conditioner other than specified herein. This warranty is in lieu of all other warranties, expressed or implied, including warranties of fitness for a particular purpose. We do not authorize any person or representative to assume for us any other obligations on the sale of this water conditioner.

### FILL IN AND KEEP FOR YOUR RECORDS

Original Purchaser	Date of Purchase	Model #	
Address of Original Installation		City	State
Dealer Purchased From	Dealer Address	City	State

Franklin Water Treatment, LLC  
12630 U.S. 33 North, Churubusco, IN 46723  
Phone: (260)693-1972 Fax: (260)693-0602