

# Installation Instructions and Owner's Manual

## OXY2 & OXY2E Series Iron Reduction System



---

---

### Franklin Water Treatment, LLC

12630 US Highway 33 N  
Churubusco, IN 46723

Phone (260) 693-1972 Fax (260) 693-0602

# Table of Contents

<b>Pre-installation Instructions</b>	<b>Page 2</b>
<b>General Installation</b>	<b>Page 4</b>
<b>Installation Instructions</b>	<b>Page 5</b>
<b>OXY2 Timer Operation</b>	<b>Page 8</b>
<b>OXY2E Display and Operation</b>	<b>Page 10</b>
<b>OXY2E Setting Time of Day</b>	<b>Page 11</b>
<b>OXY2E Programming</b>	<b>Page 12</b>
<b>Specifications</b>	<b>Page 13</b>
<b>Component Parts Breakdown &amp; List</b>	<b>Page 14</b>
<b>OXY2 Control Valve Breakdown</b>	<b>Page 15</b>
<b>OXY2 Control Valve Parts List</b>	<b>Page 16</b>
<b>OXY2E Control Valve Breakdown</b>	<b>Page 17</b>
<b>OXY2E Control Valve Parts List</b>	<b>Page 18</b>
<b>CKV-1 Coupling Check Valve Installation</b>	<b>Page 19</b>
<b>Troubleshooting</b>	<b>Page 20</b>
<b>Control Valve Wiring Diagram</b>	<b>Page 22</b>
<b>Ten Year Limited Warranty</b>	<b>Page 23</b>

# Pre-installation Instructions

## Description of the iron filtration system

The OXY2 iron filtration system includes a single filtration tank with a pocket of air and a backwashing control valve. Incoming water flows into the control valve and is directed into the filtration tank. Exposure to the air in this tank will start oxidizing the iron which is then trapped by the media. The iron-free water then returns to the control valve where it is directed into the service lines.

Periodically the control valve will go through a backwash cycle. This cycle will typically begin at 1:00 A.M. flushing the accumulated iron to the drain. Part of this backwashing process includes an air draw cycle which will replenish the pocket of air in the filter tank and prepare the unit for the next period of service.

## Water Quality

While the OXY2 filter will perform under a variety of water qualities there are a few things that need to be considered to ensure satisfactory performance. The water should be tested to determine the concentration, or levels of the items listed below.

**pH** - A measurement of the acidity of the water. pH is reported on a scale from 0 to 14. Neutral water has a pH of 7.0, lower values indicate acidic water. The OXY2 iron filter performs best when the pH is 7.0, or higher. pH values below 7.0 require a special media blend in the filter in order to elevate the pH for proper iron oxidation.

**Iron** - A naturally occurring metallic element. Iron concentrations in excess of 0.3 milligrams/liter (mg/l) combine with oxygen causing orange or red (rust) stains on plumbing fixtures. Iron naturally exists in some water sources in either clear water (ferrous) state, red water (ferric) state or bacterial form. The OXY2 iron filter is designed to oxidize ferrous iron so it can be removed by mechanical filtration in the ferric state. By removing the available iron in the water, iron bacteria are then inhibited from propagating and forming biomass. Any biomass that forms inside the iron filter is regularly dislodged during the backwash cycle of regeneration.

**Manganese** - A naturally occurring metallic element. Manganese concentrations as low as 0.05 milligrams/liter (mg/l) can combine with oxygen to cause dark brown or black staining on fixtures. Additionally, manganese can cause an odor in the water similar to a "rotten egg" smell. The OXY2 iron filter reduces manganese as well as iron, however, manganese oxidation requires the pH of the water to be elevated to 8.2 or higher. Special OXY media blends are available to elevate the pH of manganese bearing waters.

**Tannin** - A naturally occurring humic acid. Tannin is an acid caused by water passing through decaying vegetation. Coffee and Tea are prime examples of tannin in water. As hot water passes over the coffee beans, or tea leaves, the tannin is extracted causing color and flavor in the water. Tannin concentrations as low as 0.3 milligrams per liter can cause a yellow discoloration in the water and may interfere with the OXY2 iron filter's long-term ability to remove the iron as the media becomes coated with the tannic acid.

**Hydrogen Sulfide** - A naturally occurring gas. Hydrogen sulfide, more commonly referred to as sulfur gas, causes a distinct odor similar to "rotten eggs." Due to its gaseous nature, hydrogen sulfide must be tested at the well site within 1 minute of drawing the sample. If a water sample has been sitting for a while the sulfur gas will dissipate and cause the hydrogen sulfide test to be lower than the actual concentration. If sulfur is present, the filter should be set to backwash more frequently to prevent the gas from building up. The OXY2 iron filter can typically treat up to 2 milligrams per liter of sulfur gas.

# Pre-installation Instructions (cont.)

## Water Supply

Unlike other iron filters that do not use chemicals to oxidize the iron, the OXY2 iron filter does not require additional devices such as air compressors, venturis, solenoids, pressure switches or pressure tanks. This filter will function properly when the water supply is furnished by a jet pump (5 gpm minimum), submersible pump, variable speed (constant pressure) pump or community water supply. As with all other filter systems, however, it is imperative that the well pump provides enough flow rate for the filter to adequately backwash. In order to ensure sufficient backwash flow rate the following pumping rate test should be performed prior to installing the iron filter.

1. Make certain no water is being drawn in the house.
2. Open spigot nearest pressure tank.
3. When well pump starts, close spigot and measure time (in seconds) to refill pressure tank (well pump turns back off). This is **Cycle Time**.
4. Using a container of known volume, draw water from pressure tank and measure how many gallons until the pump turns back on again. This is **Draw Down**.
5. Calculate pumping rate by dividing draw down by cycle time and multiplying by 60.

$$\frac{\text{Draw Down (gallons)}}{\text{Cycle Time (seconds)}} \times 60 = \text{Pumping Rate (gallons per minute)}$$

Example: Draw down is 8 gallons  
Cycle time is 65 seconds

$$\frac{8 \text{ gallons}}{65 \text{ seconds}} \times 60 = 7.4 \text{ gpm (gallons per minute)}$$

## Location Considerations

The proper location to install the OXY2 filter will ensure optimum filter performance and satisfactory water quality. The following factors should be considered in selecting the location of the iron filter.

1. The filter should be installed after the pressure tank (private well system only).
2. The filter should be installed as close as possible (preferably within 15') to an adequate floor or laundry drain capable of handling the backwash cycle volume and flow rate (refer to unit specifications).
3. All water conditioning equipment should be installed prior to the water heater. Water temperatures exceeding 100°F can damage the internal components of the control valve and filter tank. An expansion tank may need to be installed in the line to the water heater in order to allow for thermal expansion and comply with local plumbing codes.
4. The filter should not be subject to freezing temperatures.
5. The filter should be installed before a water softener (if required).
6. Never install a cartridge type filter prior to the OXY2 iron filter. Any cartridge or in-line filter (if desired) should be installed after OXY2 filter. This will prevent restricting the water flow and pressure available for backwash.
7. Appliances requiring extended periods of continuous or high flow water use (i.e. geothermal heat pumps, swimming pools, lawn irrigation, outside hose bibs, etc.) should bypass the filter and a spring check valve should be installed on the filter inlet to prevent backflow of air from the filter tank (see installation diagram Fig. 1).
8. The installer should consider installing a vacuum breaker to prevent damage to the mineral tank and flooding if a vacuum is drawn on the system due to a city water main break or faulty check valve in a private well.

# General Installation

## GENERAL INSTALLATION & SERVICE WARNINGS

The water conditioner is not designed to support the weight of plumbing.

Do not use Vaseline, oils, other hydrocarbon lubricants or spray silicone anywhere. A silicone lubricant may be used on black "O" Rings. This will allow ease of installation and decrease chance of rolling from the bypass and tank connections. *Avoid any type of lubricants, including silicone, on red or clear lip seals.*

Do not use pipe dope or other sealants on threads. Teflon® tape must be used on the threads of the drain line connection. Teflon® tape is not used on any connection where "O" Ring seals are used

NOTE: If the plumbing system is used as the ground leg of the electric supply, continuity should be maintained by installing ground straps around any non-conductive plastic piping or bypass used in the installation.

Make sure the filter is not installed backwards. The filter will not function properly if installed backwards and filter media may be forced into the water lines. Arrows molded into the valve body and into the bypass indicate the direction of flow.

### Typical Installation

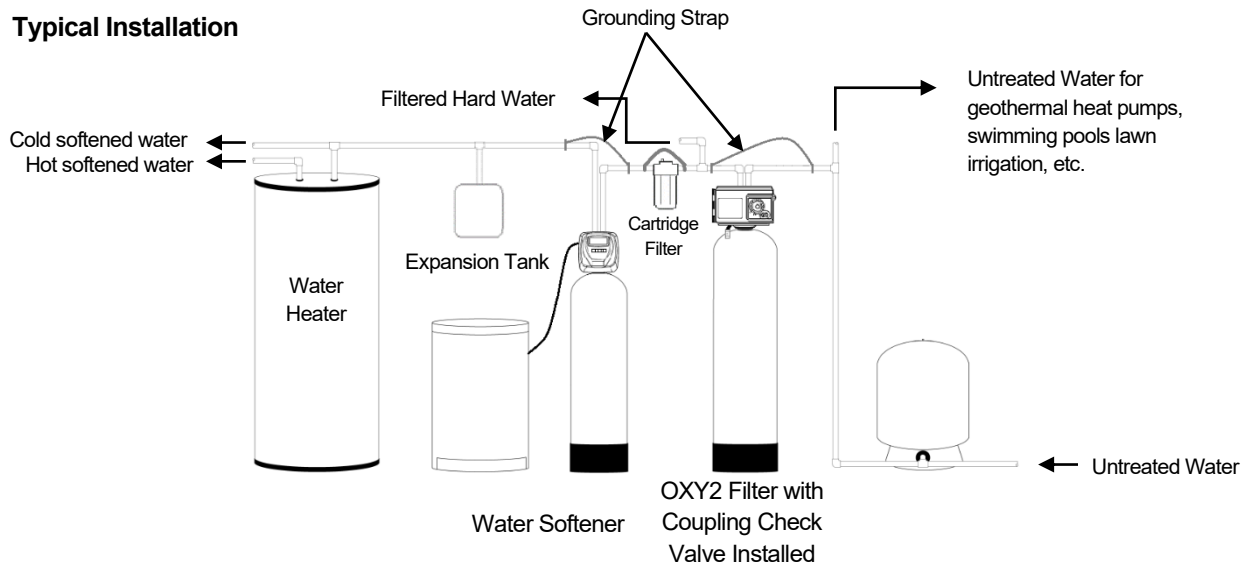

**FIGURE 1: Typical Installation**

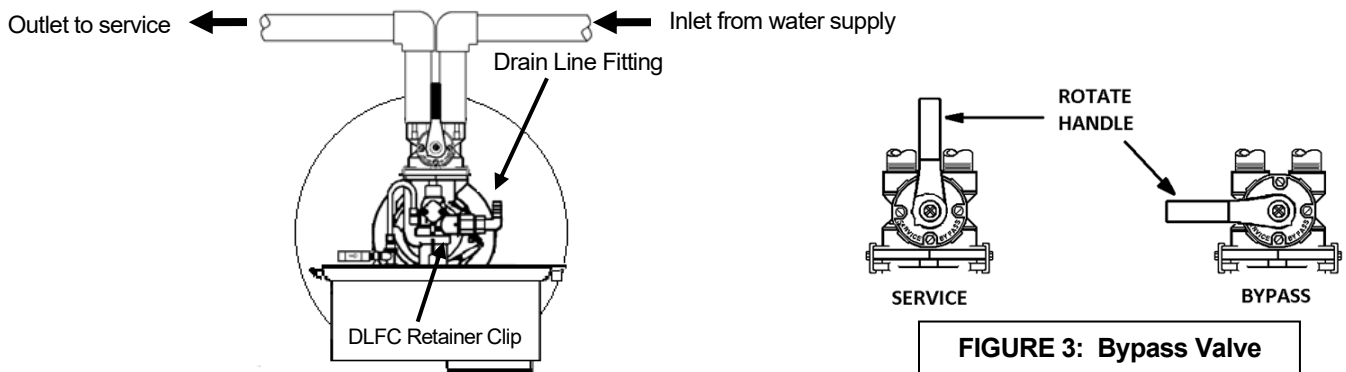

**FIGURE 2: OXY2/OXY2E Top View**

**FIGURE 3: Bypass Valve**

# Installation Instructions

- STEP 1:** If media is already loaded in filter tank proceed to Step 4. Otherwise, place red pipe cap (if provided) or a piece of tape over the end of the distributor tube to prevent media from entering the distributor tube during media filling. Make sure the distributor tube is centered and not suspended off the bottom of the tank by gravel (pre-loaded).
- STEP 2:** Use the fill funnel provided and add the provided media to the filter tank. Do not overfill the tank. At least 14" of freeboard (empty space) is required at the top of the media tank to allow for proper bed expansion during backwash.
- STEP 3:** Clean any media out of the tank threads and remove pipe cap or tape from distributor tube.
- STEP 4:** If the control valve is already installed on the filter tank; unscrew the control valve. Using a garden hose or bucket and media funnel; fill the mineral tank with water to allow the media time to saturate.
- STEP 5:** Make sure control valve pilot tube and tank thread o-rings are lubricated with silicone lubricant and screw the control valve onto the filter tank.
- If there are any branches in the plumbing between the pressure tank and the OXY you must install the CKV-1 coupling check valve and an expansion tank (Figure 1, Page 4). See CKV-1 installation instructions on page 19.**
- STEP 6:** Shut off water at main supply. Relieve pressure by opening nearest faucet. On private well systems, turn off power to pump and drain pressure tank. **SHUT OFF POWER OR FUEL SUPPLY TO WATER HEATER.**
- STEP 7:** Cut main supply line as required to fit plumbing to inlet and outlet of bypass valve. **DO NOT PLUMB INLET AND OUTLET BACKWARDS.** Piping should support control valve in an upright position. Do not apply heat to any fitting attached to the bypass or control valve.
- STEP 8:** Use the provided drain line tubing (**NO VINYL TUBING**) to run drain line from control valve discharge fitting to floor drain or sump pit capable of handling the backwash rate of the filter (refer to specifications and flow rate on page 12). **DISCHARGE END OF THE DRAIN LINE MUST BE FIRMLY SECURED!** Failure to properly secure the drain line will result in the drain line "whipping" and possibly flooding the area causing water damage. There must be an air gap at the end of the drain line to prevent siphoning of wastewater and meet plumbing code. Total length of drain line should be 15' or less. **AVOID OVERHEAD DRAINS.**

# Installation Instructions (cont.)

**STEP 9:** Plug the transformer into a non-switched electrical outlet.

Be sure the control valve is in the “Service” position. For OXY2 models the service indicator should point to the time-of-day arrow (See figure 4a below).

OXY2E units are in service when the time of day is displayed above the days remaining (see figure 6, page 10).

Open main supply valve or turn on power to the pump or private well system. Check for leaks and correct as needed.

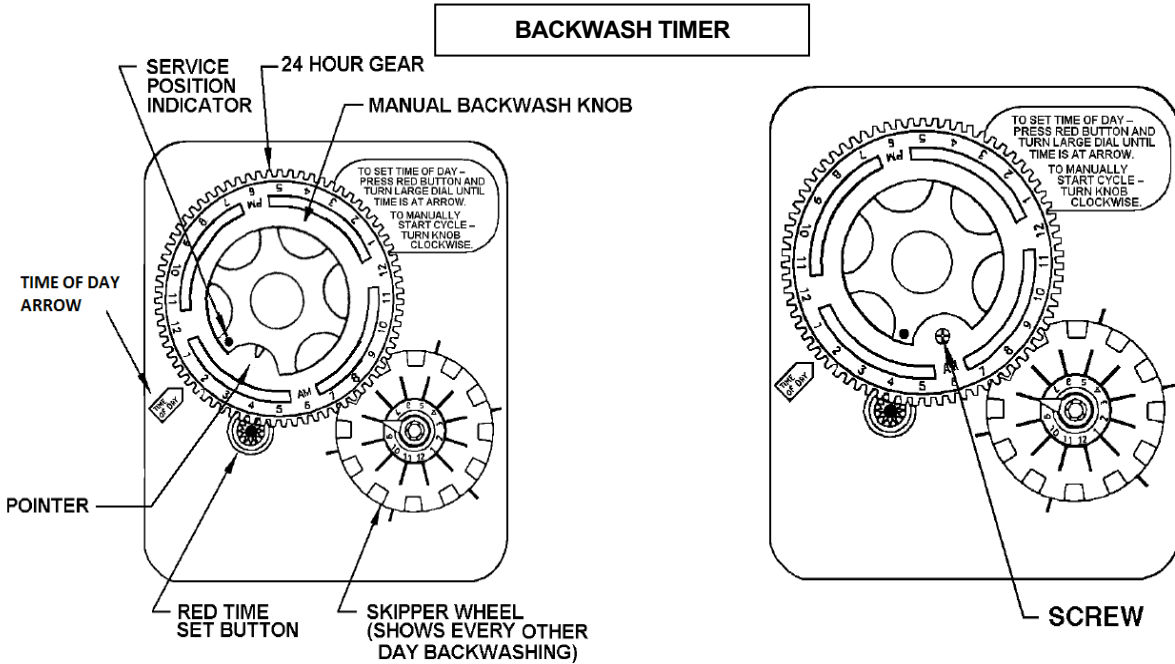

**STEP 10:** Open bypass valve  $\frac{1}{4}$  of the way allowing unit to pressurize slowly. It is normal for air to be trapped in the top part of the filter tank. Once the tank is pressurized, place bypass fully in the Service position (figure 3, page 4).

**STEP 11:** Remove media fines by manually initiating regeneration.

For the OXY2 turn the manual backwash knob (figure 4, page 8) clockwise until the drive gear engages the program wheel and water begins flowing to drain. Immediately unplug the control valve from the power outlet and leave the unit in backwash until the drain water runs clear. Meanwhile, continue with the remaining steps.

For the OXY2E hold down the middle (Advance) button (figure 6, page 10) until “GO TO BW” is displayed. Once the unit is counting down the backwash cycle time, immediately unplug the control valve from the power outlet and leave the unit in backwash until the drain water runs clear. Then, plug the control valve into the power outlet again and press the middle (Advance) button briefly, “GO TO DR” will display. Allow the regeneration cycles to complete automatically before continuing to step 13.

## Installation Instructions (cont.)

**STEP 12:** For the OXY2 set the Timer Control (Figure 4a) by rotating the Skipper Wheel (Figure 4a) so the red pointer is directly over day 1. Select the days when backwashing will occur by sliding the metal tabs in or out. IN indicates no backwashing will occur on that day, OUT indicates that backwashing will occur on that day. **Factory setting is to initiate backwash every third day.**

For the OXY2E proceed to STEP 13.

**STEP 13:** Set the current time of day. For the OXY2 start by depressing the red Time Set Button (Figure 4a) and turning the 24-Hour Gear (Figure 4a) to the desired time (note AM and PM).

For the OXY2E refer to OXY2E Series Setting Time of Day on page 11.

**STEP 14:** Time of Regeneration is factory set to 1:00 A.M. To adjust the time of regeneration for OXY2:

- a) Unplug control valve from electrical outlet
- b) Locate three screws (Figure 4b, page 6) behind the Manual Backwash Knob (Figure 4a, Page 6) by pushing the red Time Set Button (Figure 4a, page 6) and rotating the 24-Hour Gear (Figure 4a, page 6) until each screw appears in the cut-out portion of the Manual Backwash Knob.
- c) Loosen each screw slightly to release pressure on the 24-Hour gear time plate.
- d) Continue depressing the red Time Set Button and rotate the 24-Hour Gear to expose the Regeneration Time Pointer (Figure 4a, page 6) in the cut-out portion of the Manual Backwash Knob. Keep the Regeneration Time Pointer visible in the cut out while rotating only the time plate until the desired time of regeneration (note AM and PM) is aligned with the Regeneration Time Pointer. **NOTE: subtract 136 minutes from the desired time for the start of backwash to determine where the Regeneration Timer Pointer should point.**
- e) Continue depressing the red Time Set Button and rotate the 24-Hour Gear along with the Time Plate until each screw has been exposed in the cut-out portion of the Manual Backwash Knob and re-tightened. **DO NOT OVERTIGHTEN.** Make certain that the backwashing filter **DOES NOT** regenerate at the same time with any other water treatment equipment.

To adjust the time of regeneration for the OXY2E see Programming on Page 12, then continue with STEP 16.

**STEP 15:** For the OXY2, when the water flowing to drain is clear, plug the control valve back into the electrical outlet and verify the Time of Day is correct. Adjust Time of Day if necessary (see Step 13). Allow the unit to complete the regeneration cycles automatically.

**STEP 16:** Turn power or fuel supply back on to water heater.

# OXY2 Timer Operation

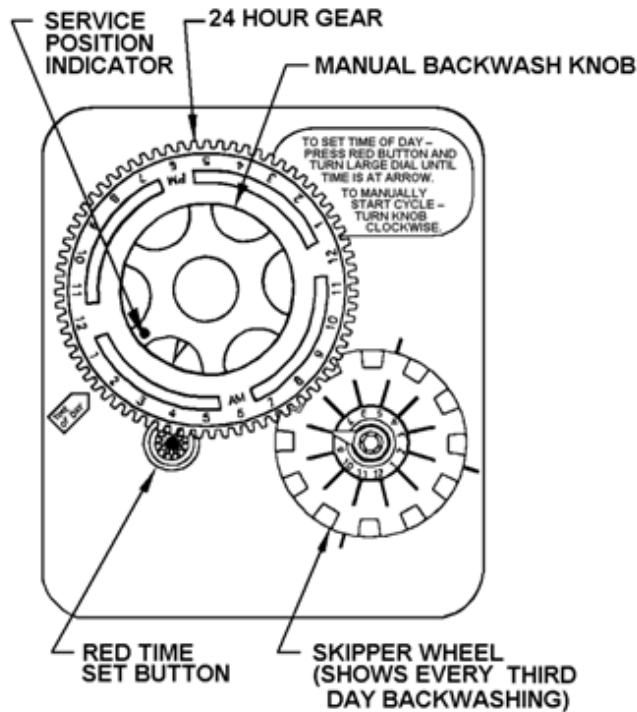

FIGURE 4: Front of Timer Assembly

## How to set Time of Day:

1. Press and hold the red button to disengage the drive gear.
2. Turn the large 24-hour gear until the actual time of day is at the time-of-day pointer.
3. Release the red button to again engage the drive gear.

## How to set the Days of Backwash:

1. Rotate the skipper wheel until the number 1 is at the red pointer.
2. Each number represents a day. The number by the red pointer is tonight.
3. Slide the metal tabs outward on the desired days of regeneration.

The OXY2 Filter should be set to backwash a minimum of every third day.

## How to Manually Initiate a Backwash Cycle:

1. Grab the manual regeneration knob and turn clockwise.
2. The drive gear will engage the program wheel and make a complete revolution through the backwash cycle.
3. The backwash knob will make a complete revolution and return to the home position after the backwash cycle.

## OXY2 Timer Operation (cont.)

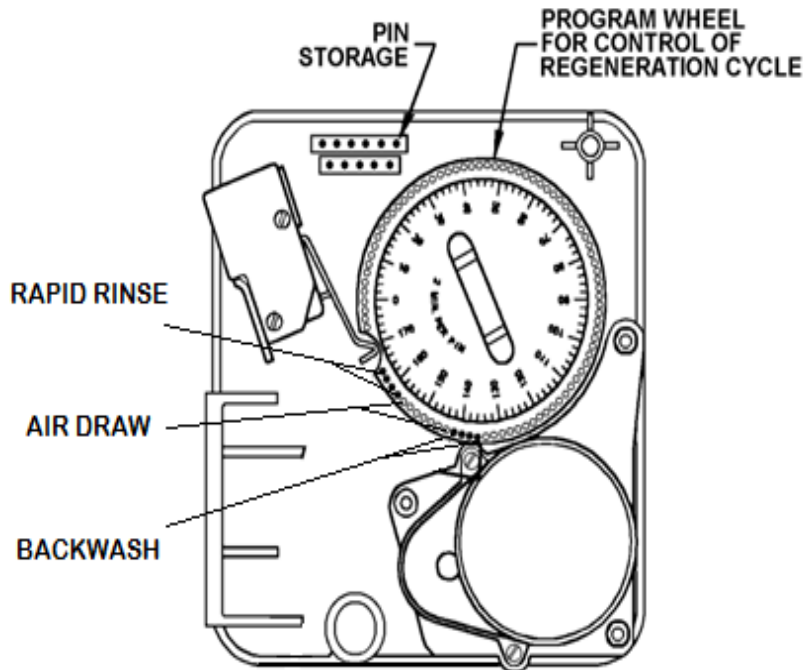

**FIGURE 5: Back of Timer Assembly**

### How to Change the Length of Backwash Cycles:

All cycles have been factory set and should not need adjustment. If local conditions require different cycle lengths, however, the following procedures should be followed. The end of the program wheel has been used for backwash cycles to minimize the amount of time that pressure will be applied to the air draw check valve.

1. Grasp top left corner of timer assembly and pull to swing timer open and expose the program wheel.
2. Remove program wheel from timer by squeezing retaining lugs in center of program wheel. Maneuver program wheel away from micro switch arms and timer assembly.
3. RAPID RINSE cycle may be lengthened by adding pins at the end of the program wheel. Each pin represents 2 minutes of rapid rinse time. The rapid rinse time **MUST** only be increased by shifting both the backwash pins and air draw holes an equal number of positions counterclockwise on the program wheel.
4. AIR DRAW cycle may be lengthened by increasing the number of holes between the two sets of pins. Each hole represents 2 minutes of air draw time. The air draw time **MUST** only be increased by moving the backwash pins counterclockwise on the program wheel. Ensure that lengthening the air draw time does not decrease either the backwash or rapid rinse times.
5. BACKWASH cycle may be lengthened by adding pins in a counterclockwise direction to first set of pins on program wheel. Each pin will equal 2 minutes of backwash time. Ensure that adding pins does not decrease air draw time.
6. Reinstall the program wheel on the retaining lugs by maneuvering past the micro switch arms.
7. Close and latch the timer assembly. Ensure that the retainer snaps into the hole in the backplate and all electrical wiring is **ABOVE** the timer post.

# OXY2E Display and Operation

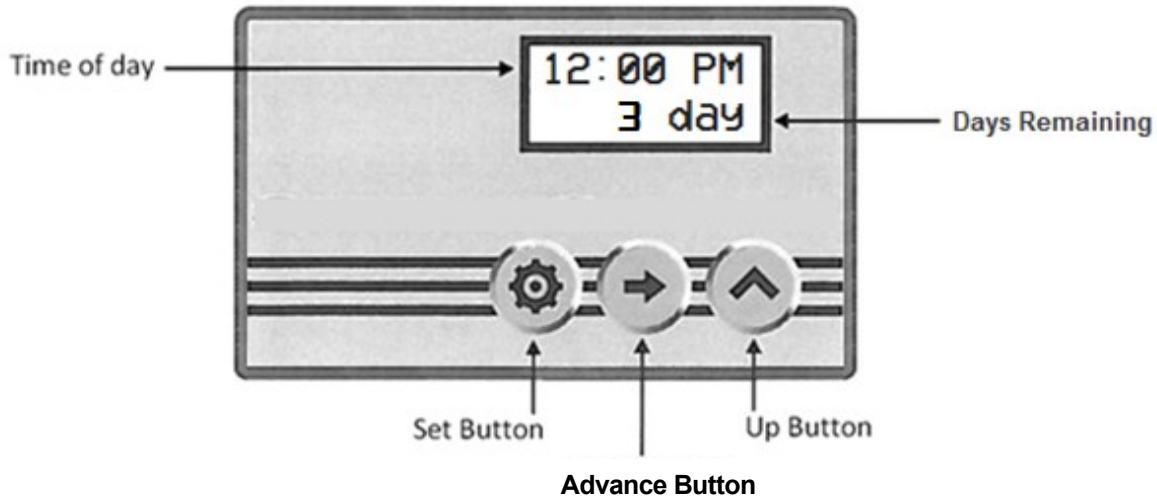

**FIGURE 6: OXY2E Display Panel**



## SET BUTTON

1. Press and hold "Set Button" for 5 seconds to enter Programming Mode.
2. When valve is in Programming Mode, press "Set Button" to confirm setting and advance to next menu option.



## ADVANCE BUTTON

1. Press and hold "Advance Button" for 5 seconds to initiate an immediate regeneration cycle.
2. Press and release "Advance Button" during a regeneration cycle to immediately advance the valve to the next step in the regeneration process.
3. When the valve is in Programming Mode, press the "Advance Button" to move the cursor.



## UP BUTTON

1. Press and hold "Up Button" for 5 seconds to initiate programming mode.
2. When the valve is in the Programming Mode, press "Up Button" to adjust setting.

# OXY2E Setting Time of Day

## Enter Programming Mode:

Press and Hold the SET Button for 5 seconds.

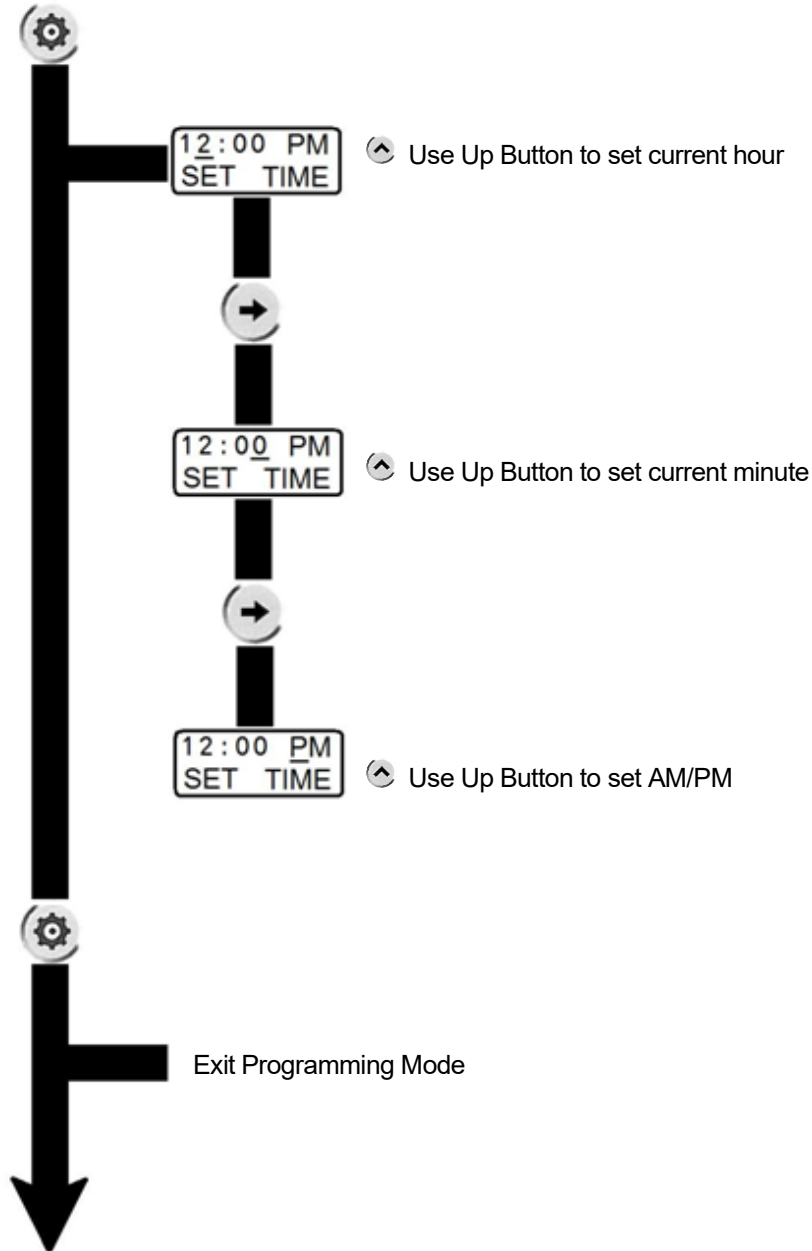

# OXY2E Programming

Press and HOLD the UP button for 5 seconds to enter the programming mode.

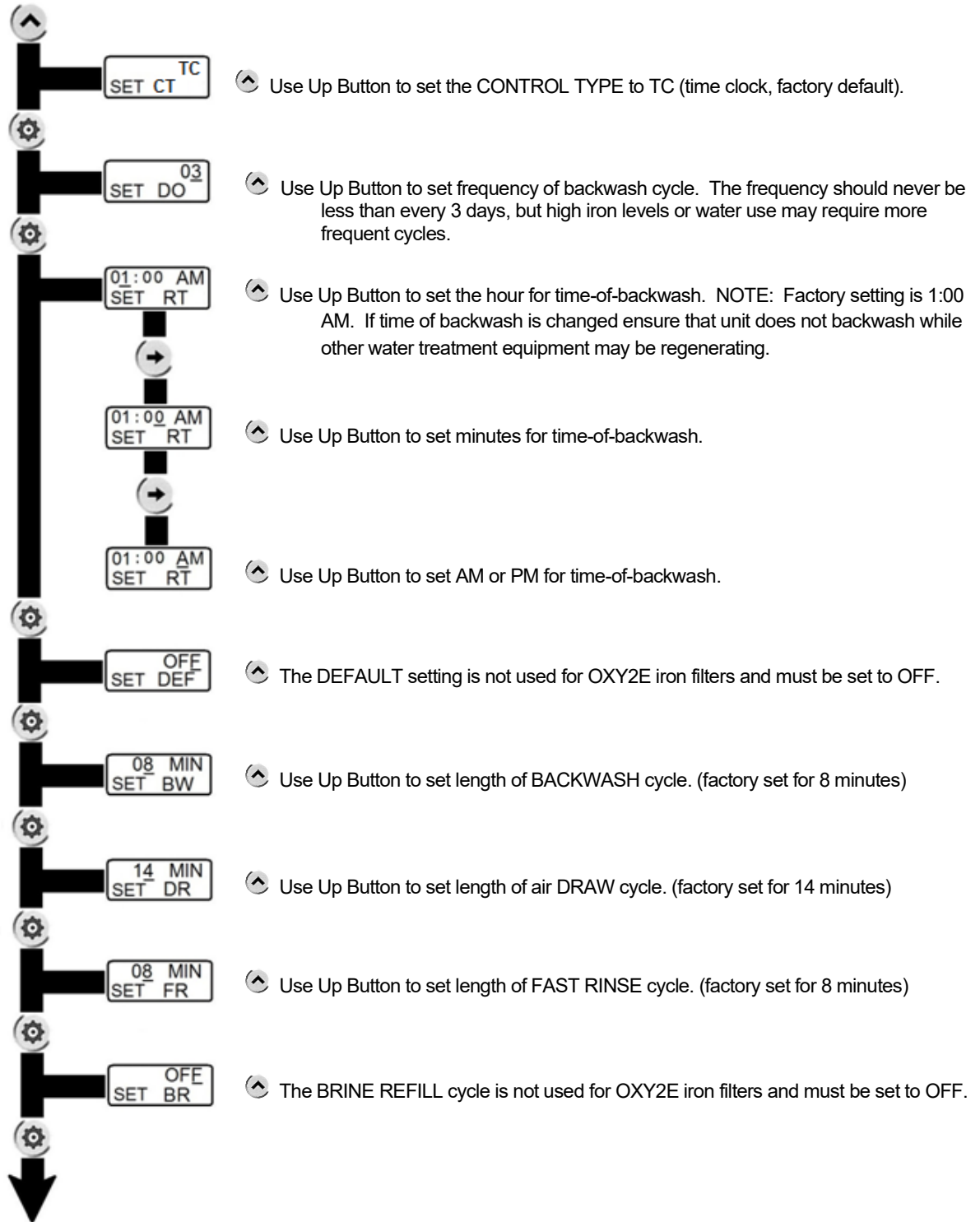

# Specifications

DESCRIPTION	OXY2-10	OXY2-20
<b>MEDIA VOLUME, cu. ft.</b>	<b>1.0</b>	<b>2.0</b>
<b>GRAVEL UNDERBED, lbs.</b>	<b>20</b>	<b>30</b>
<b>SERVICE FLOW RATES, gpm</b>		
Continuous @ 5 gpm/ft <sup>2</sup> , gpm	<b>3</b>	<b>5</b>
Peak @ 16 gpm/ft <sup>2</sup> , gpm	<b>9</b>	<b>13</b>
<b>PRESSURE LOSS<sup>1</sup>, psi</b>		
@ Continuous Flow Rate	<b>5</b>	<b>7</b>
@ Peak Flow Rate	<b>10</b>	<b>13</b>
<b>REGEN. FLOW RATES, gpm</b>		
Backwash	<b>5.0</b>	<b>7.0</b>
Air Draw and Slow Rinse	<b>0.9</b>	<b>0.9</b>
Rapid Rinse	<b>5.0</b>	<b>7.0</b>
<b>SERVICE PIPE SIZE, in.</b>	<b>1</b>	<b>1</b>
<b>FACTORY REGEN. SETTINGS</b>		
Backwash, minutes	<b>8</b>	<b>8</b>
Air Draw & Rinse, minutes	<b>14</b>	<b>14</b>
Rapid Rinse, minutes	<b>8</b>	<b>8</b>
Total Water Used, gallons	<b>93</b>	<b>125</b>
<b>DIMENSIONS, in.</b>		
Mineral Tank, diameter x height	<b>10 x 54</b>	<b>13 x 54</b>
Overall, length x width x height	<b>12 x 15 x 64</b>	<b>13 x 15 x 64</b>
DESCRIPTION	OXY2E-10	OXY2E-20
<b>MEDIA VOLUME, cu. ft.</b>	<b>1.0</b>	<b>2.0</b>
<b>GRAVEL UNDERBED, lbs.</b>	<b>20</b>	<b>30</b>
<b>SERVICE FLOW RATES, gpm</b>		
Continuous @ 5 gpm/ft <sup>2</sup> , gpm	<b>3</b>	<b>5</b>
Peak @ 16 gpm/ft <sup>2</sup> , gpm	<b>9</b>	<b>13</b>
<b>PRESSURE LOSS<sup>1</sup>, psi</b>		
@ Continuous Flow Rate	<b>5</b>	<b>7</b>
@ Peak Flow Rate	<b>10</b>	<b>13</b>
<b>REGEN. FLOW RATES, gpm</b>		
Backwash	<b>5.0</b>	<b>7.0</b>
Air Draw and Slow Rinse	<b>0.9</b>	<b>0.9</b>
Rapid Rinse	<b>5.0</b>	<b>7.0</b>
<b>SERVICE PIPE SIZE, in.</b>	<b>1</b>	<b>1</b>
<b>FACTORY REGEN. SETTINGS</b>		
Backwash, minutes	<b>8</b>	<b>8</b>
Air Draw & Rinse, minutes	<b>14</b>	<b>14</b>
Rapid Rinse, minutes	<b>8</b>	<b>8</b>
Total Water Used, gallons	<b>93</b>	<b>125</b>
<b>DIMENSIONS, in.</b>		
Mineral Tank, diameter x height	<b>10 x 54</b>	<b>13 x 54</b>
Overall, length x width x height	<b>12 x 15 x 64</b>	<b>13 x 15 x 64</b>

<sup>1</sup> Pressure loss information is approximate and may vary based on frequency and efficiency of backwash, water quality, and water use since last backwash cycle

<b>GENERAL REQUIREMENTS:</b>	Water Temperature	33°F - 100°F
	Water Pressure	25 - 100 psi
	Electrical Requirements	110v/60hz

# Component Parts Breakdown & List

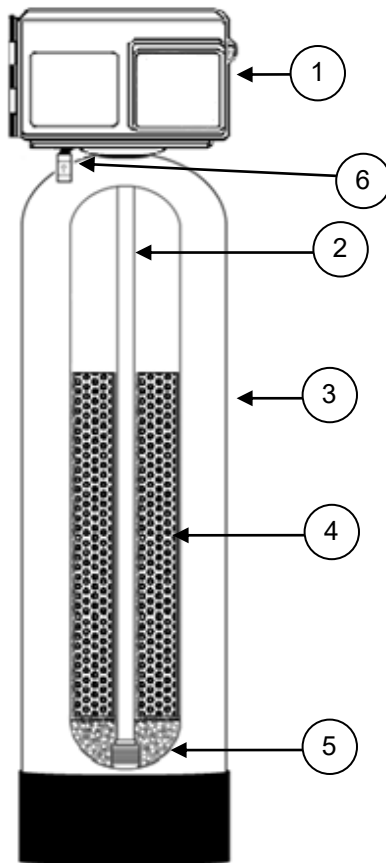

Ref #	Part Number	Description
1	OXY2-10-VLV-ASSY-L-BP- OXY2-20-VLV-ASSY-L-BP-	Complete Time Clock Control Valve less bypass valve
	OXY2E-10-VLV-ASSY-L-BP- OXY2E-20-VLV-ASSY-L-BP-	Complete Electronic Control Valve less bypass valve
2	D100S-54	Distributor Tube, 1" x 54"
3	MTP1054N	Mineral Tank, 10" x 54", OXY2-10 & OXY2E-10
	MTP1354N	Mineral Tank, 13" x 54", OXY2-20 & OXY2E-20
4	IP05	½ cubic foot pail Iron Pro Media (See specs on page 13 for amount)
	IP05M	½ cubic foot pail Iron Pro "M" Bed (See specs on page 13 for amount)
5	QC20	20 pounds ¼" x 1/8" gravel (See specs for amount)
6	JG-38CV	3/8" Check Valve

**IP05** media is recommended when incoming water pH is less than 7.0 and no manganese is present.

**IP05M** media is recommended when manganese is present in water supply.

# OXY2 Control Valve Breakdown

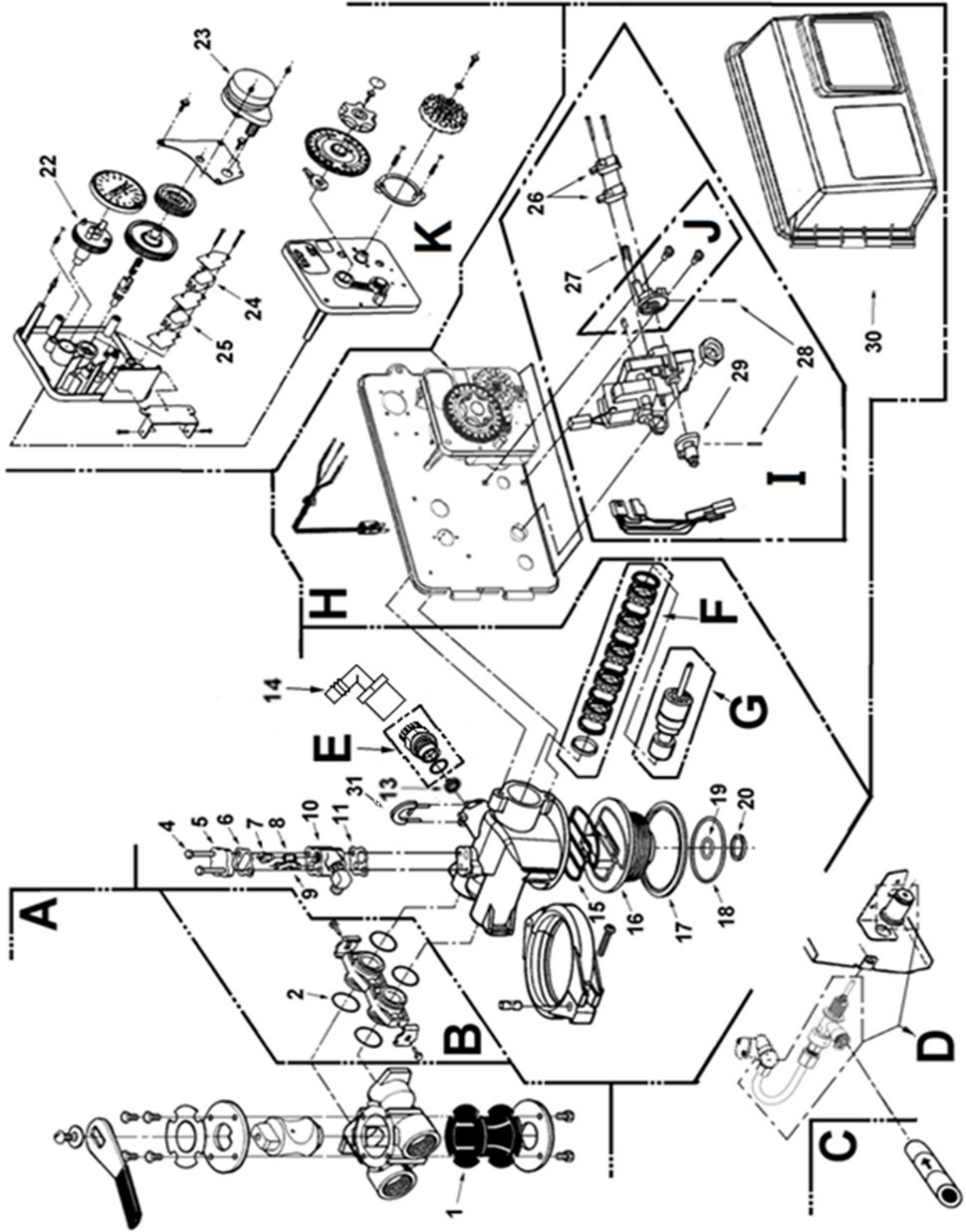

# OXY2 Control Valve Parts List

REF #	Part Number	Description
A	60041SS	Stainless Steel Bypass, 1" FPT
B	60900-41	Coupling Kit
C	JG-38CV	Check Valve, 3/8" Tube
D	1600-50	1600 Brine System Assembly, 0.5 gpm BLFC with J Tube
Not Shown	60705-50	5.0 gpm DLFC Housing (Old Style for OXY2-10)
	60705-70	7.0 gpm DLFC Housing (Old Style for OXY2-20)
Not Shown	60705-50A	5.0 gpm DLFC Barbed Elbow
	60705-70A	7.0 gpm DLFC Barbed Elbow
E	2510-DR00	Drain Fitting, 2510 Vlv, 3/4" MNPT, Less DLFC Washer
F	3600-60121	Seal and Spacer Kit
G	60090	Piston Assembly
H	FV2510-1PH	Power Head Assembly, 2510 TC with Cover
I	60050-21	Drive Motor Assembly
J	60160-10	Drive Cam Assembly, STF
K	60304-13	Timer Assembly, 3200, 12 Day, STF, 120/60
1	14105	Bypass Valve Seal, Single Lever
2	13305	Coupling O-Ring, -019
4	10692	Injector cover screw 2510 valve
5	11893	Injector Cover
6	14805	Injector Body Gasket
7	10913-2	Injector Nozzle, #2, Blue
8	10914-2	Injector Throat, #2, Blue
9	10227	Injector Screen
10	17776-10328	Injector Body Plastic w/ o-ring & brass elbow
Not Shown	21257253	O-ring for PN: 17776-10328

REF #	Part Number	Description
11	14805	Injector Body Gasket
13	12092	5.0 gpm DLFC (OXY2-10)
	12408	7.0 gpm DLFC (OXY2-20)
Not Shown	12338	Drain Fitting, Hose Barb, 90 Deg Elbow, 1/2" x 1/2" (Old Style)
14	GL463412	Drain Elbow, 3/4" Female NPT x 1/2" Barb
15	19936	Base Seal (2510)
16	3600-19322	Adapter base with distributor o-ring and o-ring retainer
17	19197	Slip Ring
18	3600-18303	Tank O-Ring, 2510 Valve
19	13304	Distributor O-Ring, -121
20	3600-13030	Distributor Retainer
Not Shown	40027	J tube for 2510 valve (Old Style)
22	13911	Main Drive Gear
23	18743-1	Timer Motor, 120v/60Hz, 2510/5600 Valve
24	15320	Micro Switch, Homing
25	10896	Micro Switch, Step
26	3600-10218	Micro Switch, Drive Motor
27	10909	Connecting Link Pin
28	10338	Roll Pin
29	12777	Brine Cam, STF
30	SCA-925	Environmental Cover (New Style)
	60219-02	Environmental Cover (Old Style)
31	3600-18312	Retainer Clip, Drain
Not Shown	CKV-1	Check Valve, Coupling, with o-rings, less clip and screw

# OXY2E Control Valve Breakdown

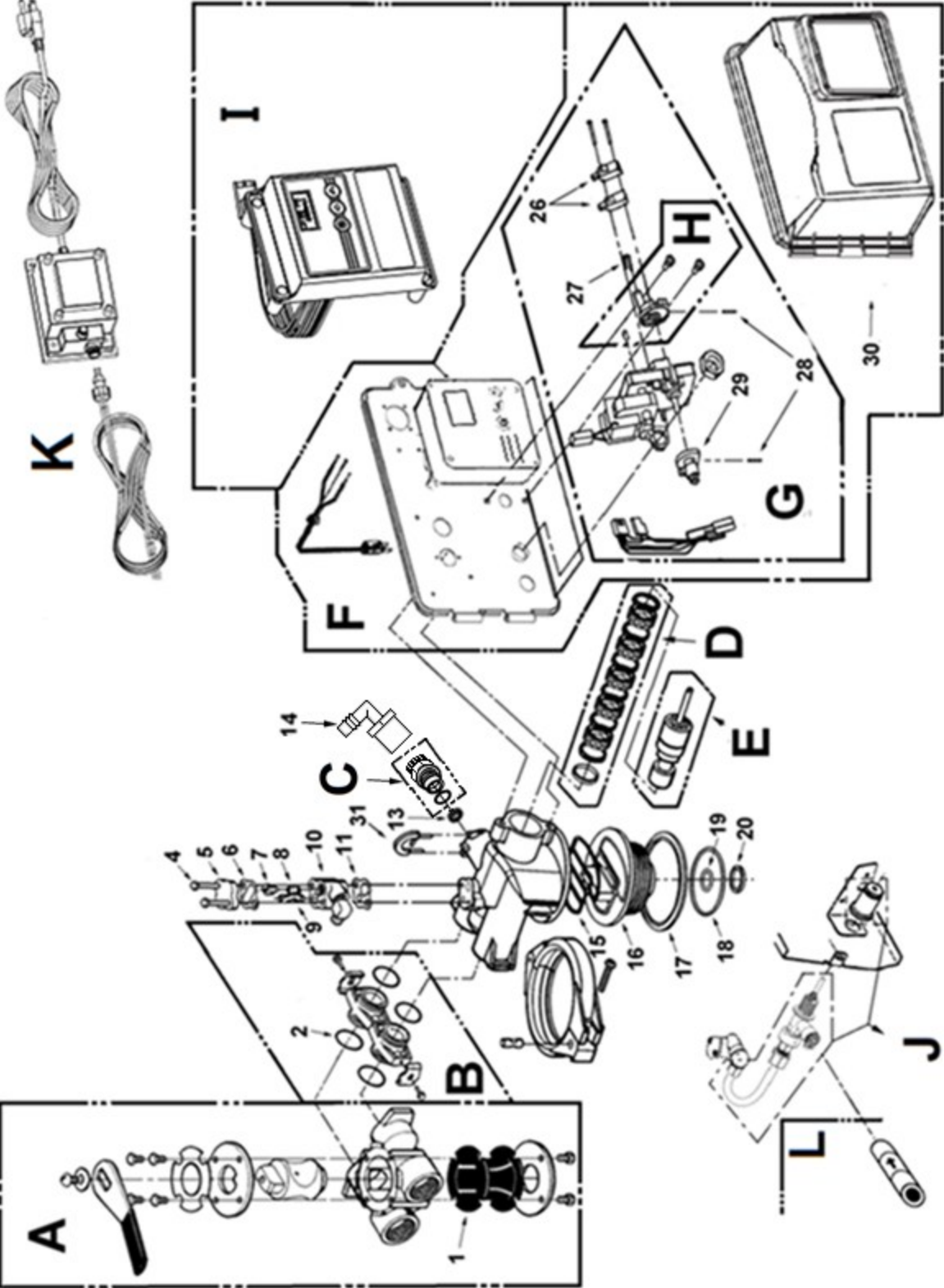

# OXY2E Control Valve Parts List

REF #	Part Number	Description
A	60041SS	Stainless Steel Bypass, 1" FPT
B	60900-41	Coupling Kit
Not Shown	60705-50A	7.0 gpm DLFC Elbow (OXY2E-10)
	60705-70A	7.0 gpm DLFC Elbow (OXY2E-20)
C	2510-DR00	Drain Fitting, 2510 Vlv, 3/4" MNPT, Less DLFC Washer
D	3600-60121	Seal and Spacer Kit
E	60090	Piston Assembly
F	FV2510E-1PH	Power Head Assembly, 2510 E with Cover
G	60050-23	Drive Motor Assembly
H	60160-10	Drive Cam Assembly, STF
I	60308-13	2510E Timer Assembly
J	1600-100	1600 Brine System Assembly, 1.0 gpm BLFC with J Tube
K	FE-TRANS	Transformer
L	JG-38CV	Check Valve, 3/8" Tube
1	14105	Bypass Valve Seal, Single Lever
2	13305	Coupling O-Ring, -019
4	10692	Injector cover screw 2510 valve
5	11893	Injector Cover
6	14805	Injector Body Gasket
7	10913-2	Injector Nozzle, #2, Blue
8	10914-2	Injector Throat, #2, Blue

REF #	Part Number	Description
9	10227	Injector Screen
10	17776-10328	Injector Body Plastic w/ o-ring & brass elbow
Not Shown	21257253	O-ring for PN: 17776-10328
11	14805	Injector Body Gasket
13	12092	5.0 gpm DLFC (OXY2E-10)
	12408	7.0 gpm DLFC (OXY2E-20)
14	GL463412	Drain Elbow, 3/4" Female NPT x 1/2" Barb
15	19936	Base Seal (2510)
16	3600-19322	Adapter base with distributor o-ring and o-ring retainer
17	19197	Slip Ring
18	3600-18303	Tank O-Ring, 2510 Valve
19	13304	Distributor O-Ring, -121
20	3600-13030	Distributor Retainer
26	3600-10218	Micro Switch, Drive Motor
27	10909	Connecting Link Pin
28	10338	Roll Pin
29	12777	Brine Cam, STF
30	SCA-925	Environmental Cover
31	3600-18312	Retainer Clip, DLFC
Not Shown	CKV-1	Check Valve, Coupling, with o-rings, less clip and screw

# CKV-1 Coupling Check Valve Installation

The check valve included with this unit replaces the coupling on the **INLET** of a water treatment unit between the bypass valve and the valve body. In units designed to maintain an air head, this check valve will prevent the loss of air when water is used prior to the water treatment unit (outside hose bibs, heat pumps, lawn irrigation, etc.).

**WARNING:** Installation of this check valve will prevent hot water expansion in the plumbing. **An expansion tank must be used on the hot water line to allow for thermal expansion.** All local plumbing codes must be followed.

## INSTALLATION:

1. If the water treatment unit was previously installed, place it in bypass position and relieve the pressure from the tank. (Refer to water treatment unit manufacturer's instructions.)
2. Remove coupling from INLET of water treatment unit. Coupling will be located between control valve and bypass valve.
3. Remove retaining clip and screw from original coupling and install on check valve coupling.
4. Install the new check valve on the INLET of the water treatment unit.

**NOTE:** Pay close attention to the direction of flow arrow molded on the side of the check valve body

5. Reconnect bypass valve, turn on water and check for leaks. (Refer to manufacturer's instructions for detailed instructions on pressurizing the water treatment unit.)

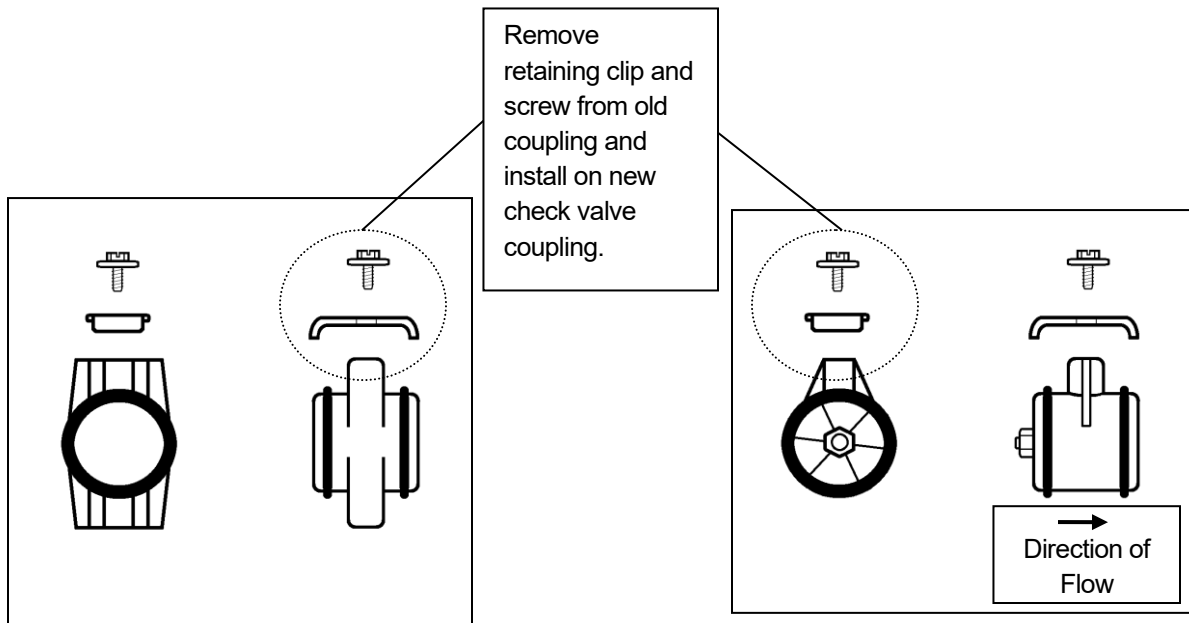

# Troubleshooting

PROBLEM	CAUSES	SOLUTIONS
Excessive pressure drop through filter	<ul style="list-style-type: none"> <li>A) Filter not backwashing</li> <li>B) Filter bed loaded with sand</li> <li>C) Insufficient backwash</li> <li>D) "Cementing" or "Channeling"</li> <li>E) Control Valve plugged with debris</li> </ul>	<ul style="list-style-type: none"> <li>1) Check timer motor and replace if faulty</li> <li>2) Ensure uninterrupted power supply</li> <li>3) Check Backwash frequency setup</li> <li>4) Verify sediment being removed is less dense than the filter media and install a "Spin-Down" type sediment filter ahead of the filter to remove well sand</li> <li>5) Increase frequency of backwash</li> <li>6) Increase length of backwash and rinse cycles</li> <li>7) Verify adequate pumping rate for backwash</li> <li>8) Probe media bed to check for "Cementing"</li> <li>9) Check drain line for restriction: frozen, plugged, kinked, exceeds 15', overhead installation, flexible drain line, drain line diameter too small</li> <li>10) Disassemble and clean control valve</li> </ul>
Water is colored from the tap	<ul style="list-style-type: none"> <li>A) Leaking bypass valve</li> <li>B) Internal valve leak</li> <li>C) Distributor not seated properly in control valve</li> <li>D) Water usage flow rate exceeds filter specifications</li> <li>E) Insufficient backwash</li> </ul>	<ul style="list-style-type: none"> <li>1) Verify bypass valve is in service position and inspect seal, replace if needed</li> <li>2) Replace spacers and seals</li> <li>3) Verify distributor tube seated securely in control valve body</li> <li>4) Verify actual water usage flow rates against system specifications</li> <li>5) Verify adequate pumping rate for backwash</li> <li>6) Increase frequency of backwash</li> <li>7) Increase length of backwash and rinse cycles</li> </ul>
Clear water turns colored after drawn	<ul style="list-style-type: none"> <li>A) Insufficient air draw</li> <li>B) Plugged injector or injector screen</li> <li>C) Open or leaking bypass valve</li> <li>D) pH too low</li> </ul>	<ul style="list-style-type: none"> <li>1) Verify air draw check valve is functioning properly and replace if needed</li> <li>2) Check drain line for restriction: frozen, plugged, kinked, exceeds 15', overhead installation, flexible drain line, drain line diameter too small</li> <li>3) Verify adequate pumping rate for backwash</li> <li>4) Increase air draw time</li> <li>5) Remove and clean injector &amp; screen</li> <li>6) Verify bypass valve is in service position and inspect seal, replace if needed</li> <li>7) Test pH. Must be 7.0 or higher or 8.2 or higher if Manganese is present (also see next troubleshooting section)</li> </ul>
Oxy media fails to raise pH sufficiently	<ul style="list-style-type: none"> <li>A) Water usage flow rate is too high to provide adequate contact time</li> <li>B) Additional steps are needed to effectively raise pH</li> </ul>	<ul style="list-style-type: none"> <li>1) Verify actual water usage flow rates against system specifications</li> <li>2) Add MpH Adder to media tank</li> <li>3) Install a chemical feed pump system ahead of the filter with Soda Ash</li> </ul>

## Troubleshooting (cont.)

<b>PROBLEM</b>	<b>CAUSES</b>	<b>SOLUTIONS</b>
Howling or whistling noise during regeneration	A) Inadequate drain line diameter or drain line restricted	1) Reconfigure or replace drain line
Control Valve cycles continually	A) Faulty switch B) Faulty timer motor	1) Replace faulty switch 2) Replace faulty timer motor
Continuous flow of water to drain	A) Loss of electrical power during regeneration B) Program wheel setup incorrectly C) Debris in control valve D) Internal leak in control valve E) Drive motor faulty	1) Ensure electrical outlet is functioning 2) Verify timer programming 3) Disassemble and clean control valve 4) Replace seals and/or piston 5) Replace faulty drive motor
Media in the service lines	A) Unit installed backwards B) Damaged distributor basket C) Insufficient gravel under bed	1) Re-plumb the water lines so that the supply side of the line is connected to the inlet of the bypass and the service side is connected to the outlet. 2) Replace damage distributor 3) Add gravel to tank & manually backwash

# Control Valve Wiring

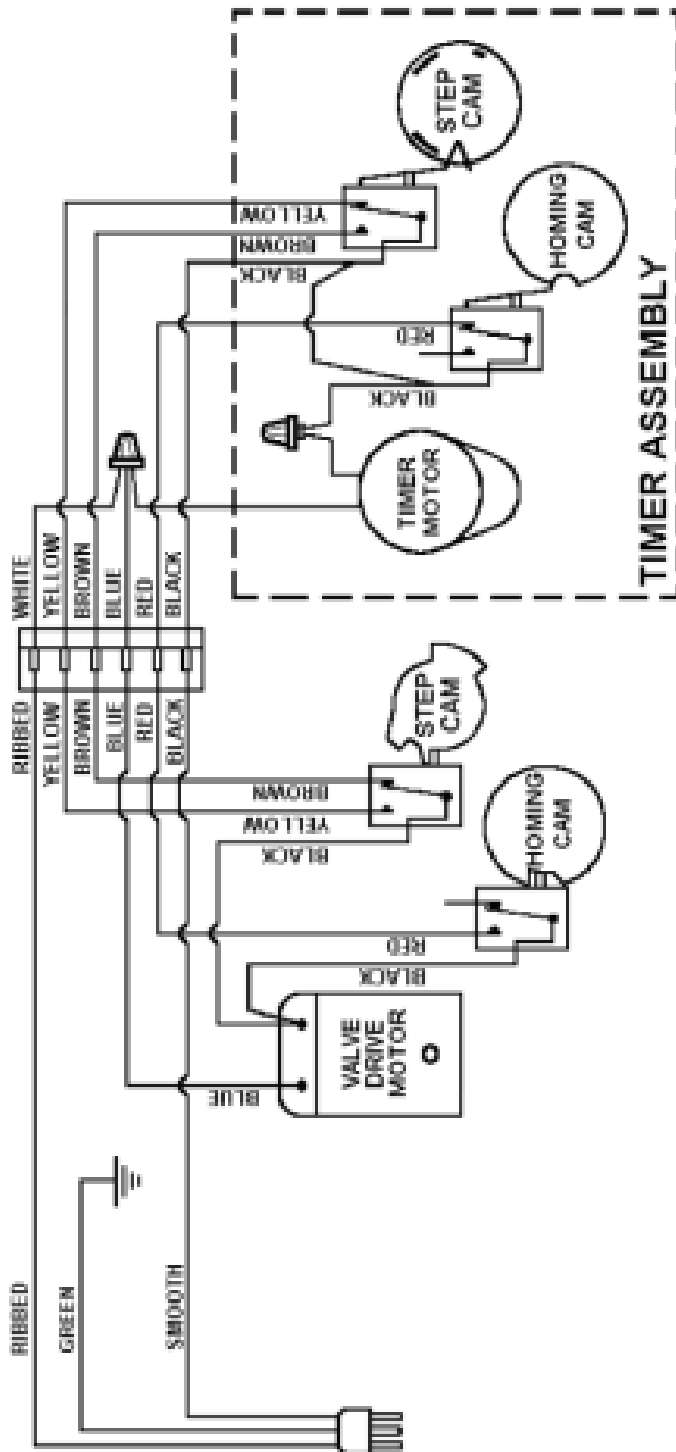

# TEN YEAR LIMITED WARRANTY

**WARRANTY – Franklin Water Treatment, LLC.** warrants this water conditioner against any defects that are due to faulty material or workmanship during the warranty period. This warranty does not include damage to the product resulting from accident, neglect, misuse, misapplication, alteration, installation or operation contrary to printed instructions, or damage caused by freezing, fire, flood, or Acts of God. From the original date of consumer purchase, we will repair or replace, at our discretion, any part found to be defective within the warranty period described below. Purchaser is responsible for any shipping cost to our facility and any local labor charges.

- One year on the entire water conditioner
- Five years on the control valve  
(Except seal & spacer kit, 1 year)
- Ten years on the mineral tank

**GENERAL CONDITIONS –** Should a defect or malfunction occur, contact the dealer that you purchased the product from. If you are unable to contact the dealer, contact Franklin Water Treatment, LLC @ (260)693-1972. We will require a full description of the problem, model number, date of purchase, and selling dealer’s business name and address.

We assume no warranty liability in connection with this water conditioner other than specified herein. This warranty is in lieu of all other warranties, expressed or implied, including warranties of fitness for a particular purpose. We do not authorize any person or representative to assume for us any other obligations on the sale of this water conditioner.

## FILL IN AND KEEP FOR YOUR RECORDS

Original Purchaser	Date of Purchase	Model #	
Address of Original Installation		City	State
Dealer Purchased From	Dealer Address	City	State

Franklin Water Treatment, LLC  
12630 U.S. 33 North, Churubusco, IN 46723  
Phone: (260)693-1972 Fax: (260)693-0602