

Installation Instructions and Owner's Manual

FEST Series Tannin / Water Softening System



Franklin Water Treatment, LLC

12630 US Highway 33 N
Churubusco, IN 46723

Phone (260) 693-1972 Fax (260) 693-0602

Table of Contents

Pre-installation Instructions	Page 2
Typical Order of Installation	Page 3
Installation Instructions	Page 4
Brine Tank	Page 5
Bypass Valve	Page 5
Day Override Calculation	Page 7
Set Time of Day	Page 9
Programming	Page 10
Model Specifications	Page 11
Component Parts Breakdown & List	Page 12
Control Valve Breakdown	Page 13
Control Valve Parts List	Page 14
Troubleshooting	Page 15
Ten Year Limited Warranty	Page 17

Pre-installation Instructions

Description of the water softener system

This tannin / water softener system includes a brine (salt) tank and a resin (media) tank with a backwashing control valve. Incoming water flows into the control valve and is directed down through the mixed bed ion exchange resin. This resin exchanges the hardness and tannin ions for sodium and chloride ions (respectively). The treated water then returns to the control valve where it is directed into the service lines.

Periodically the control valve will go through a regeneration cycle. The frequency of this regeneration process will depend on the level of tannin and hardness present in the water and the estimated daily water usage. At a minimum this unit should be regenerated every 3 days. This cycle is factory preset to begin at 3:00 A.M. At this time the control valve will draw the brine solution out of the salt tank and flush the accumulated tannin, hardness and excess salt to the drain. The control valve will then put fresh water back into the salt tank to make brine for the next regeneration cycle.

Water Quality

The water should be tested to determine the concentration, or levels of the items listed below:

IMPORTANT: If iron level is greater than 0.5 ppm, an iron filter or softener must precede the FEST. If hardness level is greater than 10 gpg, a softener must precede the FEST. A 5 micron cartridge filter must always precede the FEST.

Hardness - Hardness in drinking water is defined as those minerals that dissolve in water having a positive electrical charge (cations). The primary components of hardness are calcium (Ca++) and magnesium (Mg++) ions. But dissolved iron (Fe++) and manganese (Mn++) also contribute to total "adjusted" hardness. Hardness produces scale, soap scum and white mineral deposits which shorten the life of water using appliances, plumbing and fixtures. Water that has less than 1 grain of hardness is considered to be "soft" water.

pH - A measurement of the acidity of the water. pH is reported on a scale from 0 to 14. Neutral water has a pH of 7.0, lower values indicate acidic water. If your pH is below 6.8 you may consider installing an acid neutralizer before the water softener to elevate the pH.

Iron - A naturally occurring metallic element. Iron levels in excess of 0.3 milligrams/liter (mg/l) combine with oxygen causing orange or red (rust) stains on plumbing fixtures. Iron exists in some water sources in clear water (ferrous) state, red water (ferric) state or bacterial form. Iron levels that exceed 0.5 mg/l require an iron filter to be installed ahead of this water softener. If the iron is ferrous and iron bacteria are not present a softener could be used a pre-treatment instead of the iron filter.

Manganese - A naturally occurring metallic element. Manganese levels as low as 0.05 milligrams/liter (mg/l) can combine with oxygen to cause dark brown or black staining on fixtures. Additionally, manganese can cause an odor in the water similar to a "rotten egg" smell. This water softener may reduce manganese as well as low levels of iron; however, an iron filter may be required in some cases.

Tannin - A naturally occurring humic acid. Tannin is caused by water passing through decaying vegetation. Coffee and Tea are prime examples of tannin in water. Tannin levels as low as 0.5 milligrams per liter can cause a yellow discoloration in water. This unit can treat 1,000 ppm gallons between regenerations. I.E. – if the tannin level is 0.7, 1,000 ppm gallons ÷ 0.7 ppm = 1,428.57 gallons. NOTE: Tannin levels of 1 ppm or greater can dramatically reduce the life of iron filter media.

Hydrogen Sulfide - A naturally occurring gas. Hydrogen sulfide, more commonly referred to as sulfur gas, causes a distinct odor similar to "rotten eggs." Due to its gaseous nature, hydrogen sulfide must be tested at the well site within 1 minute of drawing the sample. If sulfur is present additional equipment will be required. An air injecting iron filter can typically treat up to 2 milligrams per liter of sulfur gas.

Pre-installation Instructions (cont.)

Location Considerations

The proper location to install the water softener system will ensure optimum performance and satisfactory water quality. The following factors should be considered in selecting the location of the equipment.

1. The water softener should be installed after the pressure tank (private well system only) or after the water meter on municipal water. Operating pressure of the softener must be limited to within 30 – 100 psi range.
2. The tannin softener should be installed as close as possible (preferably within 15') to an adequate floor or laundry drain capable of handling the backwash cycle volume and flow rate (refer to unit specifications).
3. All water conditioning equipment should be installed prior to the water heater. Water temperatures exceeding 100°F can damage the internal components of the control valve and filter tank. Install with at least 10' of pipe before the water heater to prevent thermal damage to the equipment. An expansion tank may need to be installed in the line to the water heater in order to allow for thermal expansion and comply with local plumbing codes.
4. The water softener should not be subject to freezing temperatures.
5. Ensure that any cartridge or in-line type filter installed prior to the water softener does not restrict the water flow and pressure available for backwash and interfere with normal operation.
6. Appliances requiring extended periods of continuous or high flow water use (i.e. geothermal heat pumps, swimming pools, lawn irrigation, outside hose bibs, etc.) should bypass the tannin / water softener. (see installation diagram Fig. 1).

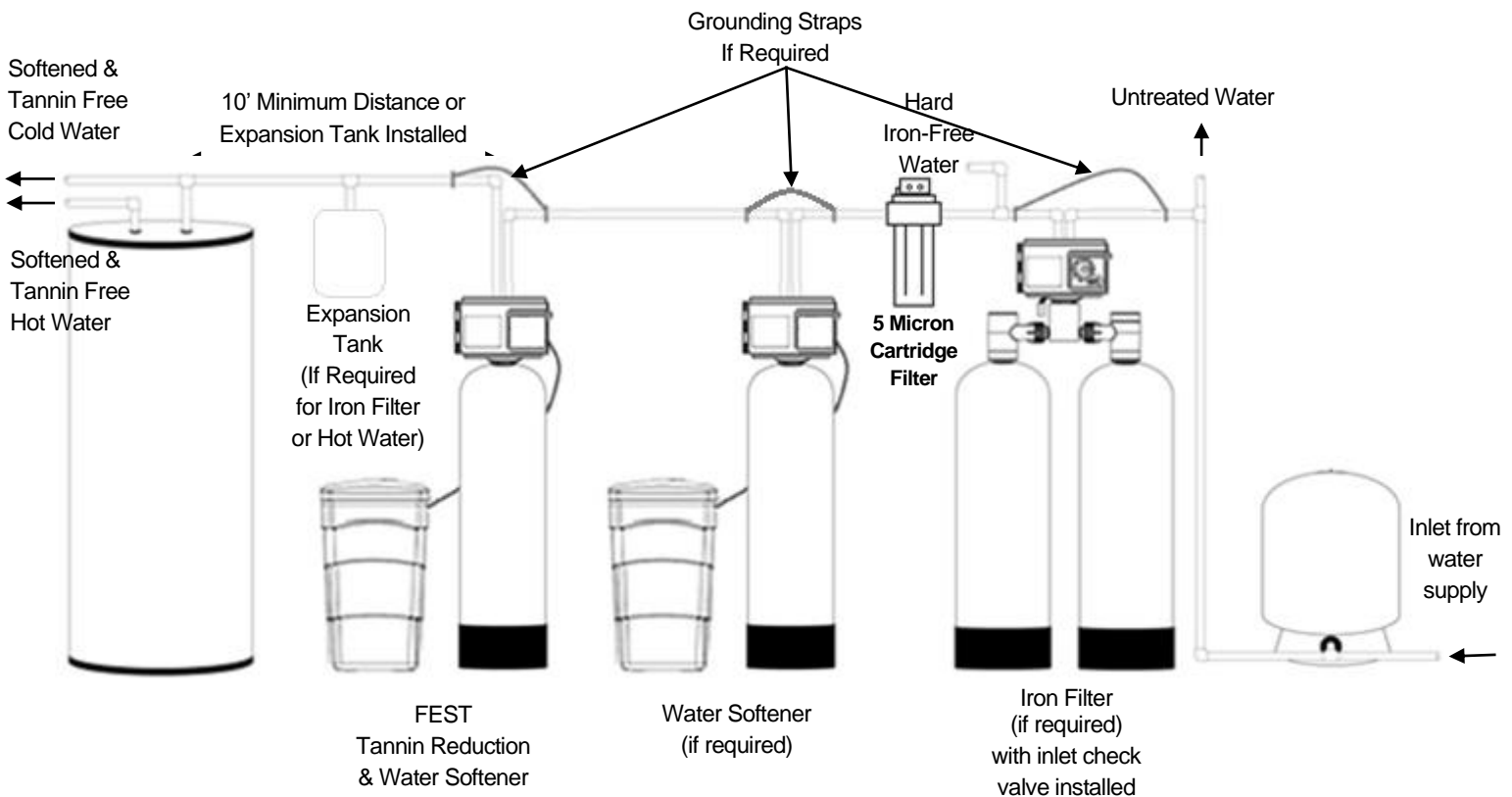

FIGURE 1: Typical Installation

Installation Instructions

STEP 1: Carefully remove all components from packaging. **DO NOT DISCARD PACKAGING** until all water softener components and fittings have been located.

STEP 2: Use clips and screws provided to connect the bypass valve to the inlet/outlet of the control valve. See figure 2 below.

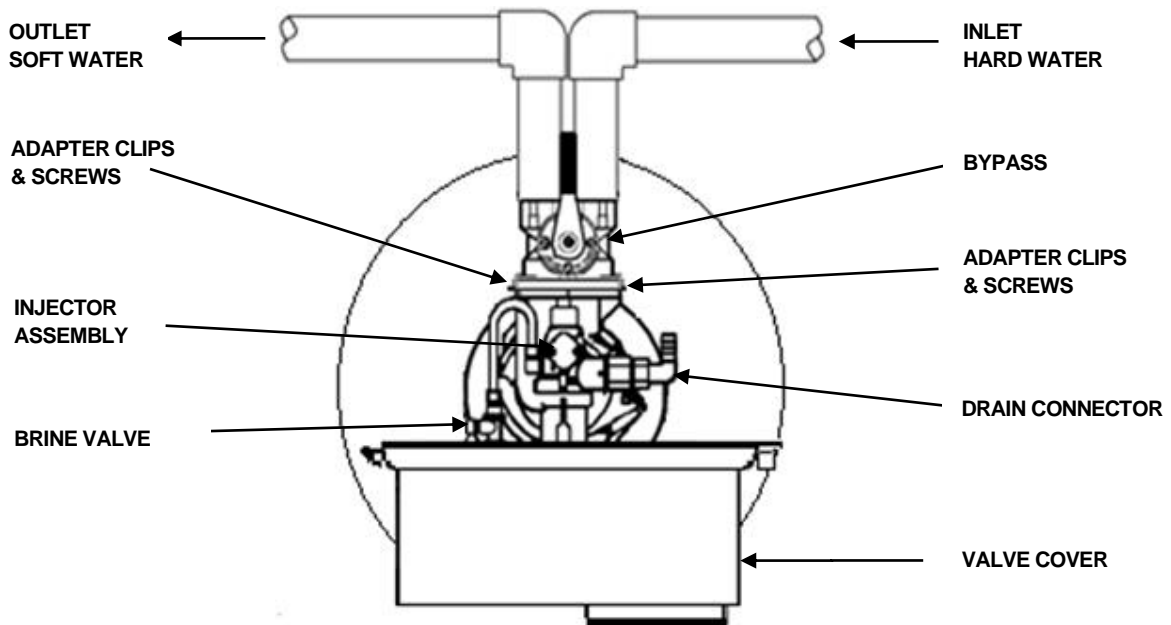

FIGURE 2: Top View of FEST Series Digital Time Clock Control Valve with Bypass

STEP 3: Place unit at desired installation position. **DO NOT plug into electrical outlet at this time (see STEP 10 on page 6). DO NOT put salt into brine tank at this time (see STEP 14 on page 6).**

STEP 4: Shut off water at main supply. Relieve pressure by opening nearest faucet. On private well systems, turn off power to pump and drain pressure tank. **SHUT OFF POWER OR FUEL SUPPLY TO WATER HEATER.**

STEP 5: Cut main supply line as required to fit plumbing to inlet and outlet of bypass valve. **DO NOT PLUMB INLET AND OUTLET BACKWARDS.** Piping should be supported. Do not apply heat to any fitting attached to the bypass or control valve.

STEP 6: Use polyethylene drain line tubing provided (**NO VINYL TUBING**) to run drain line from control valve discharge fitting to floor drain or sump pit capable of handling the backwash rate of the softener (refer to specifications and flow rate on page 11). **DISCHARGE END OF THE DRAIN LINE MUST BE FIRMLY SECURED!** There must be an air gap at the end of the drain line to prevent siphoning of waste water and meet plumbing code. Total length of drain line should be 15' or less. **AVOID OVERHEAD DRAINS.**

Installation Instructions (cont.)

- STEP 7:** Connect one end of the provided 3/8" brine line to the control valve quick connect fitting. Insert the other end of the brine line through the hole in the brine tank and into the quick connect fitting on the safety brine valve. Remove the quick connect collet retainer clip (if included) before inserting the brine line into each fitting, press the tube in very firmly and replace the retainer clip behind the collet. **NOTE: THE BRINE TUBING SHOULD BE INSERTED 5/8" INTO THE FITTING. DO NOT PUT SALT INTO THE BRINE TANK AT THIS TIME (See STEP 13).**

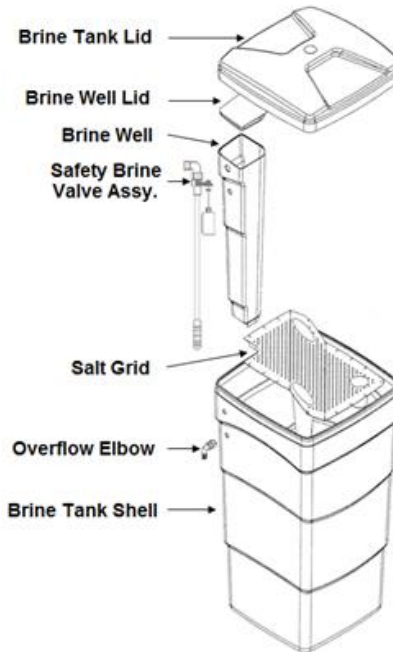

FIGURE 3: Brine Tank Components

- STEP 8:** Install overflow tubing (not included) from overflow elbow on brine tank to floor drain. Tubing must be lower than overflow elbow at all times. **DO NOT CONNECT DRAIN LINE FROM SOFTENER CONTROL VALVE TO BRINE TANK OVERFLOW. DO NOT CONECT BRINE TANK OVERFLOW TUBING TO THE SOFTENER DRAIN LINE.**
- STEP 9:** Place bypass valve in the "Bypass" position (refer to Figures 4 below). Open main supply valve or turn on power to pump on private well systems.

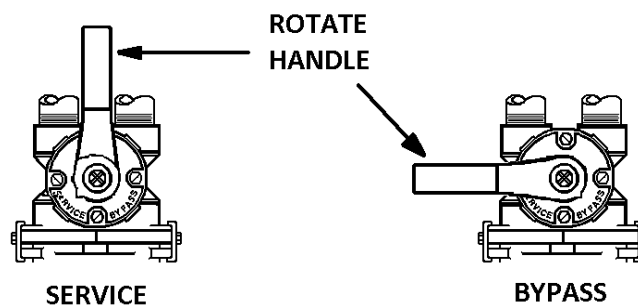

FIGURE 4: Stainless Steel Bypass Valve Operation

Installation Instructions (cont.)

- STEP 10:** Plug the transformer into an un-switched electrical outlet and the control valve power cord into the transformer. Then press and hold down the center “ADVANCE” button (middle button that looks like a right pointing arrow) until “GO TO BW” appears on the screen. Wait until the valve reaches the backwash position before going to STEP 11 (a countdown timer will appear on the display).
- STEP 11:** Unplug the softener from the electrical outlet to keep it in the backwash position.
- Refer to Figure 4 (page 5) for appropriate bypass valve operation. Rotate bypass lever of the stainless steel bypass $\frac{1}{4}$ of the way to “Service” allowing unit to fill slowly. You should hear water trickling into the mineral tank. Filling the mineral tank in this position will force any trapped air to the drain. **When all air has been purged from the system and only water is running to the drain, slowly open the bypass valve fully to the service position.**
- STEP 12:** While waiting for the mineral tank to fill, use a bucket or hose to put water in the brine tank up to the top level of the salt grid and verify the brine line is inserted as far as possible into the quick connect fittings at both ends of the brine line.
- STEP 13:** Plug the softener back into the electrical outlet. Press the “ADVANCE” button briefly and the control valve will go to the “BRINE DRAW” position (“GO TO DR” will display). Once the cycle countdown begins, verify that the water level in the brine tank is dropping. If the water level does not drop, refer to page 15 of Troubleshooting.
- STEP 14:** Advance the control valve through “FAST RINSE” to the “BRINE REFILL” cycle by pressing the “ADVANCE” button briefly to display “GO TO FR” and then “ADVANCE” again when the “FR” cycle countdown begins in order to display “GO TO BR”. Allow the softener to complete the “BRINE REFILL” cycle automatically to put water into the brine tank for the next regeneration. **Add salt to the brine tank at this time.**
- STEP 15:** Check for leaks and correct as necessary.
- STEP 16:** Turn on power or fuel supply back on to water heater.
- STEP 17:** Set Time of Day. Press the “SET” button (far left button that looks like a gear) until the screen changes to “SET TIME”. Set the current time of day using the “UP” button (far right button that looks like a caret symbol above the number 6 on a keyboard) to change the hours, minutes and AM/PM and use the “ADVANCE” button to change between hours, minutes and AM/PM and use the “UP” button to change the values. Press the “SET” button to return to the main display.
- STEP 18:** Set the “DAY OVERRIDE” or “DO” based on the calculation on page 7:
- A. press and hold the “UP” button until the screen displays “SET CT”. Verify that “TC” is displayed in the upper right of the screen. If not, use the “UP” button to change the value to “TC”.
 - B. Briefly press the “SET” button. The screen will display “SET DO”. If the value displayed (default is 3) does not match the “DO” you calculated, use the “UP” button to change it. *NOTE: To set a value lower than the one on the screen you will have to use the “UP” button until the value passes 28. It will then increment beginning with “OFF”, then 1, 2, 3.*

Installation Instructions (cont.)

- C. Press the "SET" button to display the regeneration time (default 3:00 AM). It may be changed using the "UP" and "ADVANCE" buttons in the same manner as setting the time of day.
- D. Press the "SET" button to display the unit size definition ("SET DEF"). The default for FEST45 is "MEDIUM", for FEST60 the default is "LARGE"

Press the "SET" button to return to the main display.

How to Calculate the "DAY OVERRIDE":

Calculate the number of gallons that can be treated for tannin, divide 1,000 by the tannin level. Then divide that result by estimated daily water use (dropping all fractions) to determine the maximum number of days between regenerations for tannin reduction.

"DO" = $((1,000 \div \text{tannin mg/l or ppm}) \div (\# \text{ people} \times 75 \text{ gal. per day}))$ dropping any fractional portion of the result.

Example: Tannin = 1.7 ppm, 3 people in family
3 people x 75 gallons per day = 225 gallons per day usage
1,000 ppm gallons \div 1.7 ppm tannin = 588.24 gallons capacity
588.24 gallons capacity \div 225 gallons usage per day = 2.61 days
Drop fractional portion = 2

Result: Set tannin softener to regenerate once every 2 days

FEST Display and Operation

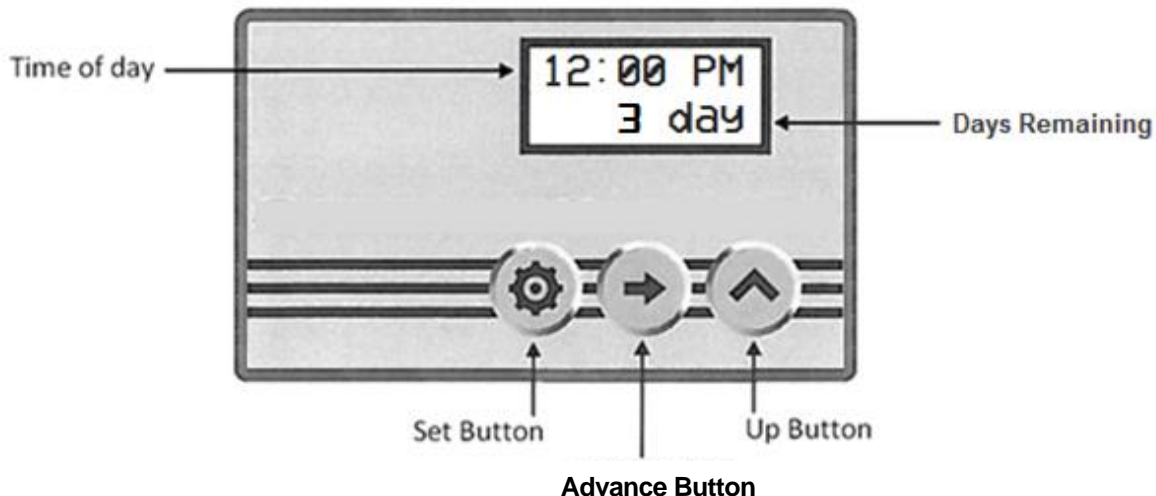

FIGURE 5: FEST Display Panel



SET BUTTON

1. Press and hold "Set Button" for 5 seconds to enter Programming Mode.
2. When valve is in Programming Mode, press "Set Button" to confirm setting and advance to next menu option.



ADVANCE BUTTON

1. Press and hold "Advance Button" for 5 seconds to initiate an immediate regeneration cycle.
2. Press and release "Advance Button" during a regeneration cycle to immediately advance the valve to the next step in the regeneration process.
3. When the valve is in Programming Mode, press the "Advance Button" to move the cursor.



UP BUTTON

1. When the valve is in the Programming Mode, press "Up Button" to adjust setting.

FEST Set Time of Day

Enter Programming Mode:

Press and Hold the SET Button for 5 seconds.

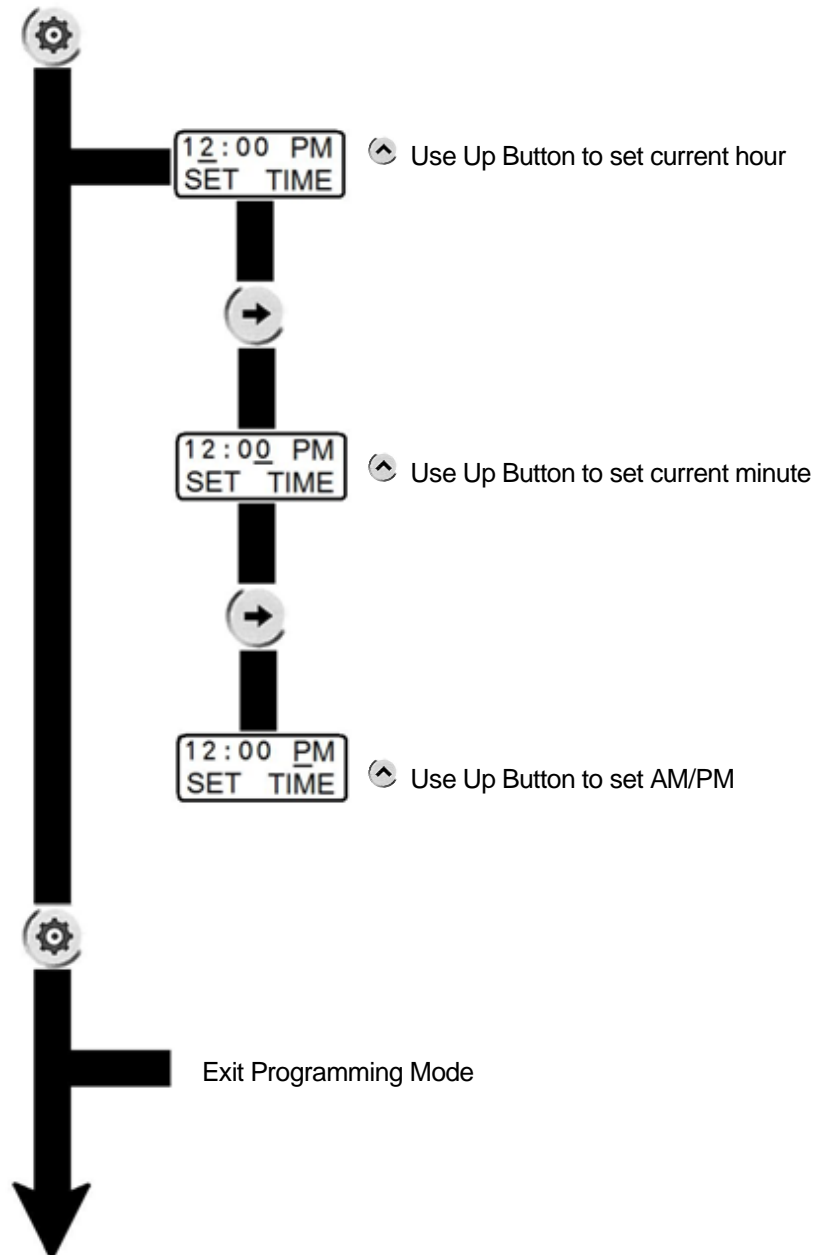

FEST Programming

Press and HOLD the UP button for 5 seconds to enter the programming mode.

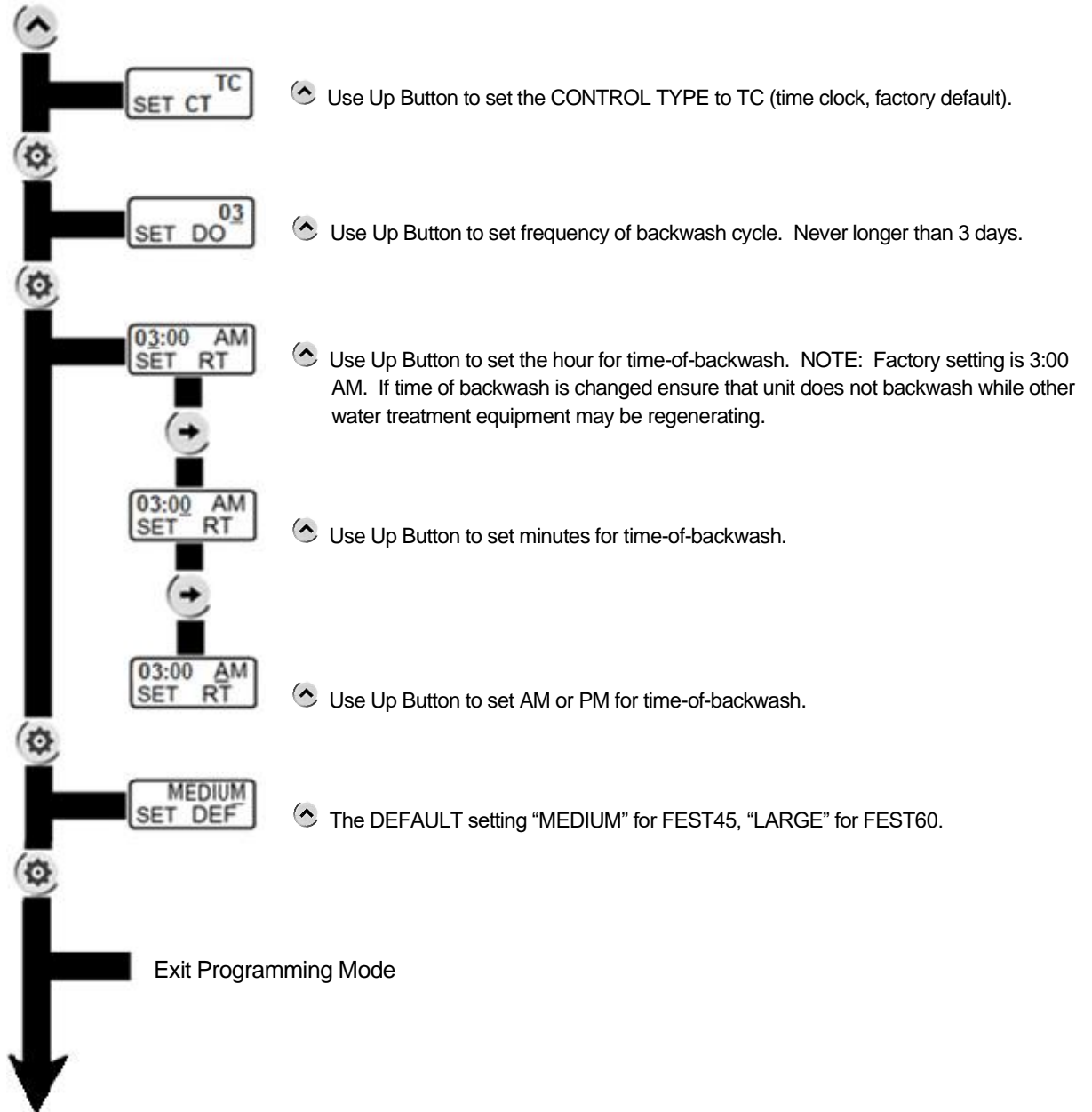

Specifications

DESCRIPTION	UNIT MODEL NUMBER	
	FEST45	FEST60
MEDIA VOLUME, ft³	1.5	2.0
HARDNESS CAPACITY, grains Factory Salt @ 9 lb/ft ³ (146 g/L)	24,000	29,000
TANNIN CAPACITY, ppm gallons Factory Salt @ 9 lb/ft ³ (146 g/L)	1,000	1,000
SERVICE FLOW RATES, gpm Cont. (3 gpm/ ft ³ cation resin)	3	4
Service (5 gpm/ ft ³ resin)	8	10
Peak (Max. 20 psi drop)	14	16
PRESSURE LOSS, psi @ Continuous Flow Rate	2	3
@ Service Flow Rate	8	9
@ Peak Flow Rate	19	19
REGENERATION FLOW RATES, gpm Backwash	2.4	3.0
Brine Draw / Slow Rinse	0.38 / .45	0.56 / 0.84
Rapid Rinse	2.4	3.0
FACTORY REGENERATION SETTINGS Preliminary Rinse (minutes)	--NA--	--NA--
Backwash (minutes)	6	8
Brine & Rinse (minutes)	60	60
Rapid Rinse (minutes)	6	6
Brine Fill (# of salt)	12	18
Total Water Used (gallons)	58	96
DIMENSIONS, inches Mineral Tank (diameter x height)	10 x 54	12 x 48
Brine Tank (diameter x height)	14 x 34	18 x 33
Overall (depth x width x height)	14 x 25 x 63	18 x 31 x 57

GENERAL REQUIREMENTS:

Iron <= 0.5 ppm
 Hardness <= 10 gpg
 110v/60hz
 4.17 amps

Component Parts Breakdown

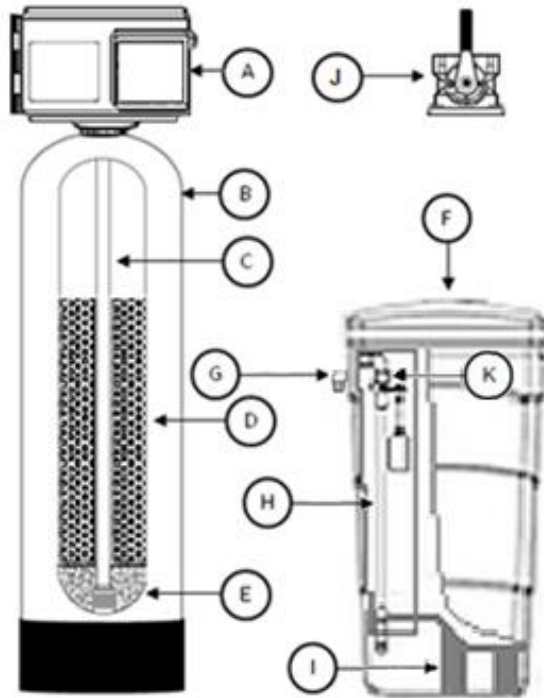

Ref	Description	Model Number	
		FEST45 ¹	FEST60 ¹
A	Timeclock Valve w/ 3/4" stainless steel bypass	FEST45 ¹ Vlv Assy W/BP	FEST60 ¹ Vlv Assy W/BP
B	Mineral Tank	MTP1054GR	MTP1248GR
C	Distributor	D100S-54	D100S-48
D	Tannin Resin & Hi Cap Resin	(1) T05P (2) H05P	(1) T05P (3) H05P
E	1/4" X 1/8" Gravel	Qty 1 QC20	Qty 1 QC20
F	Brine Tank Assy.	BT1434ASSY	BTSQ1833ASSY
G	Overflow Fitting	BT-OVERFLO	BT-OVERFLO
H	Safety Brine Valve	SBV14ASSY	SBV14ASSY
I	Salt Platform	BTSG14	BTSG18SQ
J	Bypass ² (stainless steel)	60040SS ²	60040SS ²
*	Top Screen (not shown)	18280-02	18280-02

1. -1S suffix for 1" FPT stainless steel bypass (60041SS).

FEST Control Valve Breakdown

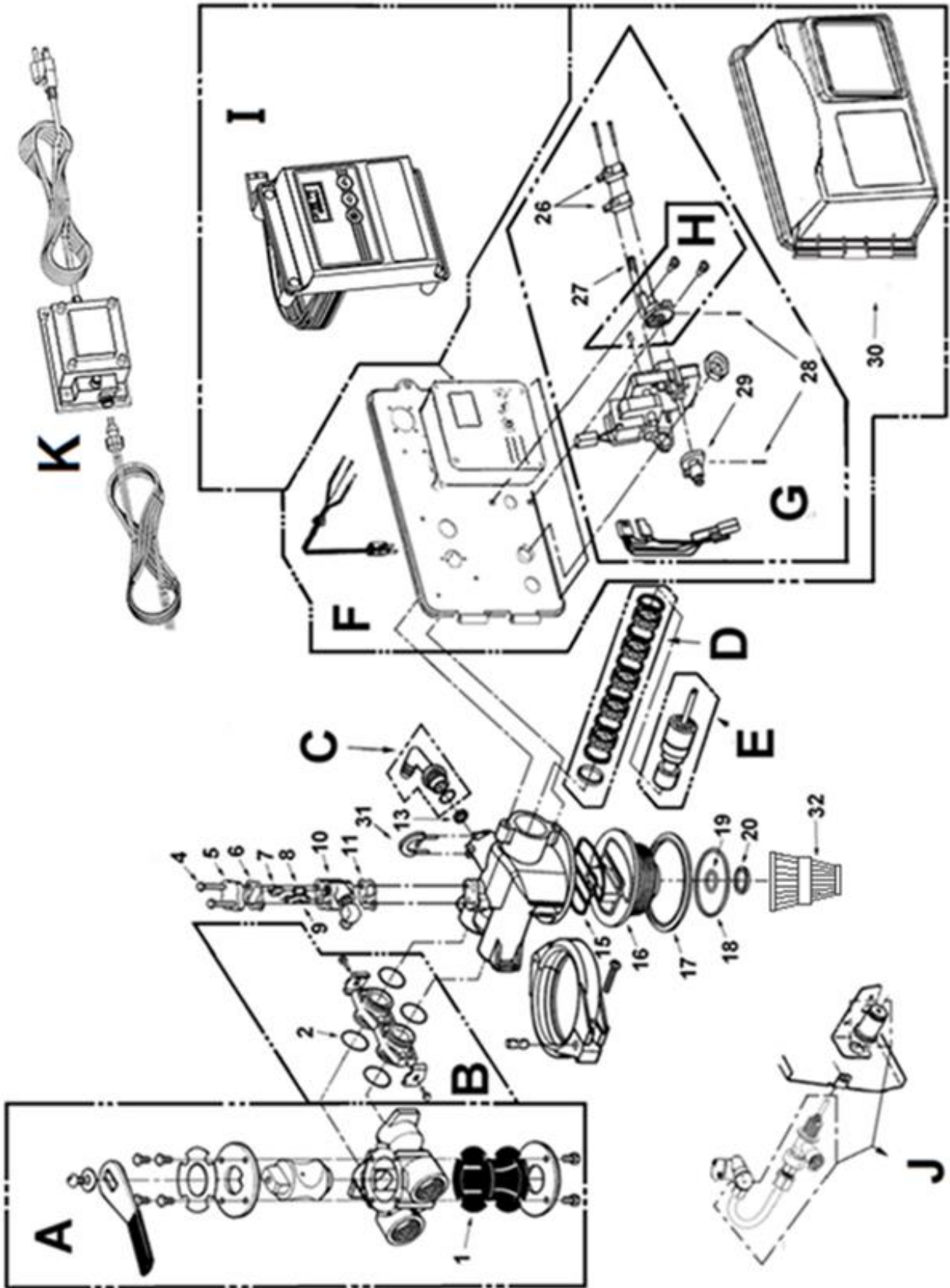

FEST Control Valve Parts List

REF #	Part Number	Description
A	60040SS	Stainless Steel Bypass, ¾" FPT
	60041SS	Stainless Steel Bypass, 1" FPT
B	60900-41	Coupling Kit
C	60705-00A	DLFC Elbow, barbed, less flow button
D	60121	Seal and Spacer Kit
E	60090	Piston Assembly
F	FV2510E-1PH	Power Head Assembly, 2510 E with Cover
G	60050-23	Drive Motor Assembly
H	60160-10	Drive Cam Assembly, STF
I	60308-13	2510E Timer Assembly
J	60011-050ASSY	Brine Valve, 1650 Short Stem, 0.5 BLFC with Tube
K	FE-TRANS	Transformer
1	14105	Bypass Valve Seal, Single Lever
2	13305	Coupling O-Ring, -019
4	10692	Injector cover screw 2510 valve
5	11893	Injector Cover
6	14805	Injector Body Gasket
7	10913-1	Injector Nozzle, #1, White (FEST45)
	10913-2	Injector Nozzle, #2, Blue (FEST60)
8	10914-1	Injector Throat, #1, White (FEST45)
	10914-2	Injector Throat, #2, Blue (FEST60)

REF #	Part Number	Description
9	10227	Injector Screen
10	17776/10328	Injector Body Plastic w/ o-ring & brass elbow
Not Shown	21257253	O-ring for PN: 17776/10328
11	14805	Injector Body Gasket
13	12088	2.4 GPM DLFC (FEST45)
	12089	3.0 GPM DLFC (FEST60)
15	19936	Base Seal (2510)
16	3600-19322	Adapter base with distributor o-ring and o-ring retainer
17	19197	Slip Ring
18	18303	Tank O-Ring, 2510 Valve
19	13304	Distributor O-Ring, -121
20	13030	Distributor Retainer
26	10218	Micro Switch, Drive Motor
27	10909	Connecting Link Pin
28	10338	Roll Pin
29	12777	Brine Cam, STF
30	SCA-925	Environmental Cover
31	18312	Retainer, DLFC
32	18280-02	Top Screen, Bayonet Style

Troubleshooting

PROBLEM	CAUSE	SOLUTION
1. Unit fails to regenerate	A. Electrical service to unit has been interrupted	A. Ensure permanent electrical service to unit (switch, circuit breaker, plug, etc.)
	B. Faulty control board	B. Replace control board
	C. Defective valve drive motor	C. Replace drive motor
	D. Improper unit programming	D. Check programming and correct as needed
2. Unit delivers untreated water	A. Bypass valve is open	A. Close bypass valve
	B. No salt in brine tank	B. Add salt to brine tank and maintain salt level above water level
	C. Injectors or screen plugged	C. Clean or replace injectors and screen
	D. Insufficient water flowing into brine tank	D. Check brine tank fill time and clean brine line flow control
	E. Leak at distributor tube	E. Check length of distributor tube and pilot tube o-ring
	F. Internal valve leak	F. Replace piston and seals/spacer kit
	G. Improper configuration	G. Increase the frequency of regeneration
3. Unit uses too much salt	A. Improper configuration	A. Verify salt setting is 9 lb/cu ft and decrease frequency of regeneration if appropriate
	B. Excessive water in brine tank	B. See Problem # 7
4. Loss of water pressure	A. Softener too small for application	A. Check application requirements and resize water softener as required
	B. Foreign material buildup in plumbing system or water softener	B. Clean or replace plumbing, as necessary, additional treatment equipment may be required
5. Loss of resin through drain line	A. Air in water system	A1. Check for low water table conditions in well A2. Check for positive seal on brine line connections
	B. Drain line flow control is too large	B. Ensure proper drain line flow control is installed
6. Iron in treated water	A. Water is improperly pre-treated	A. Test incoming water supply and install OXY Series iron filter prior to softener, as needed.
	B. Iron fouled resin	B. Install proper pre-treatment equipment. Use resin cleaner to remove iron fouling.
7. Excessive water level in brine tank	A. Restricted drain flow control	A. Clean drain line flow control
	B. Drain line too long or installed overhead or restricted	B. Verify drain line is not restricted or improperly installed
	C. Vinyl drain line was used	C. Replace drain line with rigid or semi-rigid material with no kinks and as few elbows as possible
	D. Brine valve sticking (soft water)	D. Replace brine valve assembly
	E. Injector/screen plugged (hard water)	E. Clean or replace injectors and screen
	F. Improper configuration	F. Verify salt setting is 9 lb/cu ft
	G. Either end of the brine line is loose	G. Tighten loose brine line connections

Troubleshooting (continued)

PROBLEM	CAUSE	SOLUTION
8. Salty water after regeneration	A. Injectors or screen plugged	A. Clean or replace injectors and screen
	B. Restricted drain flow control	B. Clean drain line flow control
	C. Brine valve sticking	C. Replace brine valve assembly
	D. Brine tank is overfilled	D. See Problem # 7
	E. Rinse cycle too short	E. Lengthen rinse cycle
9. Water leaks to drain continuously	A. Foreign material in control valve	A. Remove and inspect piston and seal kit. Replace as necessary
	B. Drive motor stopped during regeneration cycle	B. Check for obstruction in piston and seals. Replace drive motor. Inspect condition of power head gears
	C. Control valve continuously cycling	C. See Problem #10
	D. Internal valve seal leak	D. Replace seals and/or piston
10. Control valve continuously cycling	A. Faulty homing switch	A. Replace homing switch

TEN YEAR LIMITED WARRANTY

WARRANTY – Franklin Water Treatment, LLC warrants this water conditioner against any defects that are due to faulty material or workmanship during the warranty period. This warranty does not include damage to the product resulting from accident, neglect, misuse, misapplication, alteration, installation or operation contrary to printed instructions, or damage caused by freezing, fire, flood, or Acts of God. From the original date of consumer purchase, we will repair or replace, at our discretion, any part found to be defective within the warranty period described below. Purchaser is responsible for any shipping cost to our facility and any local labor charges.

- One year on the entire water conditioner
- Five years on the control valve
(Except seal & spacer kit, 1 year)
- Ten years on the mineral tank

GENERAL CONDITIONS – Should a defect or malfunction occur, contact the dealer that you purchased the product from. If you are unable to contact the dealer, contact Franklin Water Treatment, LLC @ (260)693-1972. We will require a full description of the problem, model number, date of purchase, and selling dealer’s business name and address.

We assume no warranty liability in connection with this water conditioner other than specified herein. This warranty is in lieu of all other warranties, expressed or implied, including warranties of fitness for a particular purpose. We do not authorize any person or representative to assume for us any other obligations on the sale of this water conditioner.

FILL IN AND KEEP FOR YOUR RECORDS

Original Purchaser	Date of Purchase	Model #	
Address of Original Installation		City	State
Dealer Purchased From	Dealer Address	City	State

Franklin Water Treatment, LLC
12630 U.S. 33 North, Churubusco, IN 46723
Phone: (260)693-1972 Fax: (260)693-0602