

# INSTALLATION MANUAL

## DSF-PFOA Point-of-Use PFA's Reduction System



---

Franklin Electric Co., Inc.  
12630 US 33 N.  
Churubusco, IN 46723  
Ph. (260) 693-1972 Fax (260) 693-0602

DS-PFOA Manual 250128

# TABLE OF CONTENTS:

<b>SECTION I.</b>	<b>INTRODUCTION AND LIABILITY.....</b>	<b>3</b>
<b>SECTION II.</b>	<b>SPECIFICATIONS.....</b>	<b>3</b>
<b>SECTION III:</b>	<b>PREPARATION.....</b>	<b>4</b>
	<i>A. Major System Components.....</i>	<i>4</i>
	<i>B. Tools Recommended for Installation.....</i>	<i>4</i>
	<i>C. Determine System Location.....</i>	<i>4</i>
	<i>D. Prepare the Area for Installation.....</i>	<i>5</i>
	<i>E. Prepare the Appliance for Installation.....</i>	<i>5</i>
<b>SECTION IV.</b>	<b>INSTALLATION STEPS.....</b>	<b>5</b>
	<i>A. Install the Faucet.....</i>	<i>5</i>
	1. Make the Faucet Mounting Hole.....	5
	2. Mount the Faucet.....	6
	<i>B. Install the Feed Water Valve and Tubing.....</i>	<i>6</i>
	<i>C. Automatic Water Meter.....</i>	<i>7</i>
	<i>D. Setting the Shut-off Meter.....</i>	<i>7</i>
	<i>E. Make Final Tubing Connections &amp; Install the Leak Stop Valve.....</i>	<i>7</i>
	<i>F. Install Ice Maker Hookup (optional).....</i>	<i>7</i>
	<i>G. Start up the system.....</i>	<i>7</i>
	<i>H. Flush System and Check Operation.....</i>	<i>7</i>
<b>SECTION V:</b>	<b>OPERATION &amp; MAINTENANCE.....</b>	<b>8</b>
	<i>A. Changing Filters.....</i>	<i>8</i>
	<i>B. Exploded Diagram.....</i>	<i>9</i>
	<i>C. Parts List.....</i>	<i>10</i>
	<i>D. Quick Connect Fittings.....</i>	<i>11</i>
<b>SECTION VI:</b>	<b>TROUBLESHOOTING GUIDE.....</b>	<b>12</b>
	<b>Leak Stop Valve Compressed Pellet Replacement.....</b>	<b>13</b>
	<b>LIMITED WARRANTY.....</b>	<b>14</b>

## SECTION I. INTRODUCTION

Congratulations, you have just purchased one of the finest Point-of-Use PFA's Reduction Appliances available.

Like any other fine product, this appliance requires periodic maintenance in the form of filter changes. Your system comes pre-set at 1900 gallons. If the meter counts down to zero or the filters haven't been changed in 6 months, then in either case it's time for a filter change.

Your new PFA's Reduction (DSF-PFOA) Drinking Water system uses a combination of Ion Exchange Resin and a carbon block filter to remove the widest range of PFA's found in our drinking water.

## SECTION II. SPECIFICATIONS

**TABLE A – RECOMMENDED OPERATING LIMITS FOR FEED WATER**

<b>Specifications</b>	<b>DSF-PFOA</b>
Water Pressure	40-80 psig
Temperature	40-100°F
pH	5-9
Hardness	Less than 1 gpg
Iron	Less than 0.05 ppm
Manganese	Less than 0.05 ppm
Alkalinity	200 ppm max
Chloride	100 ppm max
Sulfate	200 ppm max
Bacteria	Must be potable**

**\*\*DO NOT USE WITH WATER THAT IS MICROBIOLOGICALLY UNSAFE OR OF UNKNOWN QUALITY.**

**TABLE B – SYSTEM SPECIFICATIONS**

<b>Specifications</b>	<b>DSF-PFOA</b>
Overall Height	15"
Overall Width	11"
Overall Depth	5.5"
I/O	1/4"
Flow Rate	0.5 gpm

## LIABILITY

All information and recommendations appearing in this manual concerning the use of products described herein are based on information contained in good faith but makes no representation as to its comprehensiveness or accuracy. However, it is the user's responsibility to determine the suitability for his/her own use of such products. Since the actual use by others is beyond our control, no guarantee, expressed or implied, is made by Franklin Electric Co., Inc. (FECI) as to the effects of such use or the results to be obtained. FECI assumes no liability arising out of the use by others of such products. Nor is the information herein to be construed as absolutely complete, since additional information may be necessary or desirable when particular or exceptional conditions or circumstances exist or because of applicable laws or government regulations.

## SECTION III: PREPARATION

### A. Major System Components

The following components comprise the DSF-PFOA Drinking Water System:

1. A PFA's Reduction assembly consisting of the steel bracket, filter housings, PFA's and Carbon Block filters, installed shut-off ball valve with fittings.
2. An automatic shut-off water meter with installed fittings on the OUTLET.
3. A faucet kit with 1/4" fittings.
4. A plastic tubing kit with feed water supply valve and leak stop valve.
5. Other items necessary for installation may include wood screws or machine screws for mounting the DSF-PFOA assembly, concrete anchors may be required for hanging on basement wall, additional tubing or tube connectors, and plastic wire ties for organizing tubing.

### B. Tools Recommended for Installation

The following tools will cover most of the installation sites encountered:

- 3/8" variable speed electric drill.
- Extension work light with outlet.
- Safety Glasses.
- 1-1/4" porcelain hole cutter kit.
- 1-1/4" Greenlee hole punch and 1/8" and 1/2" metal drill bits for pilot hole.
- Center punch and hammer.
- 1-1/4" wood bit.
- Assorted wood and metal drill bits including 7/32" metal drill bit.
- Phillips head and flat blade screwdrivers.
- 1/2", 9/16" and 5/8" open end wrench.
- 10" Crescent wrench with jaws taped to hold faucet.
- Teflon tape.
- Wide masking tape or duct tape.
- Plastic tubing cutter.
- Extra plastic tubing.
- Small bottle of liquid chlorine bleach.

### C. Determine System Location

The DSF-PFOA system can be located under a sink or in a basement depending on space availability and the customer's preference. If a basement installation is selected, additional tubing, hardware and fittings may be needed and a hole will have to be made from inside the cabinet, through the floor, to the basement. Never install in an area of the home where temperature is freezing as damage to the system will result.

Considerations for an ice maker or other remote hook up should be determined, including routing and any additional tools, fittings, and tubing that may be required.

- 1) Faucet - The faucet should be placed near the sink where drinking water is normally obtained. Convenience of use (filling of water pitchers and glasses), and an open area beneath the faucet under the sink for attaching product tubing are considerations. A 2" diameter flat surface is required above and below the mounting site. The thickness of the mounting surface should not exceed 1-1/4". Watch for strengthening webbing on the underside of cast iron sinks.
- 2) DSF-PFOA Assembly - The DSF-PFOA Assembly may be mounted on either the right or left side of the under-sink area or a cabinet. Mounting in the basement is also an option. The mounting location should allow adequate clearance and accessibility for cartridge changes.
- 3) Feed Water Connection - The feed water valve should be located as close to the DSF-PFOA assembly as possible.
- 4) Leak Stop Valve – Drinking water systems inherently have many connections which could leak. It is necessary to install the included Leak Stop Valve very close to and/or under the DSF-PFOA assembly. It must be fastened to the floor or cabinet base with screws or double-sided tape. The feed water supply must pass through the Leak Stop Valve (See page 9). Should a leak occur, and the underside of the Leak Stop Valve gets wet, the feed water will be terminated. Once activated, the Leak Stop Valve can be reset one time (See page 13).

#### D. Prepare the Area for Installation

Clear the area under the sink prior beginning the installation.

If a basement installation is called for, determine where components will be located and how they will be mounted. Special mounting brackets and hardware may be necessary to secure the system to a wall or ceiling joists.

Inspect cold water supply line to determine if any special fittings, in addition to what is included in the kit, are required

#### E. Prepare the Appliance for Installation

Open shipping carton and remove components. Check that all installation parts are present which includes the DSF-PFOA assembly, water meter, faucet, installation hardware, leak stop valve, tubing, and wrench.

### SECTION IV. INSTALLATION STEPS

All plumbing should be done in accordance with state and local plumbing codes.

**NOTE:** Some codes may require installation by a licensed plumber; check with the local plumbing authority prior to installation.

In restricted under-sink areas, it may be easier to install the faucet first. Allow adequate tubing lengths for any final component position.

#### A. Install the Faucet

##### See Figure 1 for Faucet Installation Diagram

The faucet should be positioned so that it empties into the sink and the spout swivels freely for convenience.

If the sink already has a hole provided that can accommodate the DSF-PFOA faucet, then no drilling is required and you can proceed to the section on mounting the faucet.

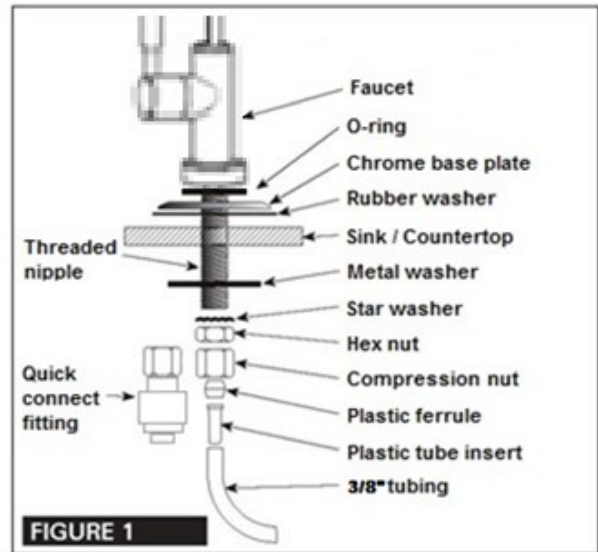

#### 1. Make the Faucet Mounting Hole

**IMPORTANT:** It is mandatory that safety glasses be worn during sink hole drilling operations to prevent eye injury.

Before starting the hole making operation, always check below the sink so that nothing interferes with mounting the faucet such as reinforcing ribs, support brackets or cabinet construction.

#### STAINLESS STEEL SINK:

Recommended tools:

- Center punch
- Variable speed drill and high speed drill bits.
- Greenlee chassis punch 7/8" hole size (alternate 9/16" size may be used for non air gap faucet)
- Protective gloves

Procedure:

- a) Center punch a small indent at the desired faucet location.
- b) Slowly drill the required pilot hole for the chassis punch.
- c) Set up the chassis punch per instructions and tighten nut to cut the desired hole size.
- d) Clean up sharp edges with a file if necessary.

## **PORCELAIN/ENAMEL/CERAMIC ON SHEET METAL OR CAST IRON BASE:**

Recommended tools:

- Variable speed drill
- Relton porcelain cutter tool set 7/8" size (alternate 9/16: size may be used for air gap or non-air gap faucet)
- Plumber's putty

It is important to understand what is involved in this procedure. First, the glassy layer of porcelain must be penetrated through to the base metal. Second, a center disc of porcelain must be removed while protecting the surrounding porcelain against chipping or fracturing. Third, the base metal must be drilled through to complete the hole.

Procedure:

- a) Mark the center for the 7/8" hole
- b) Form shallow putty dam around hole area and fill with enough water to lubricate carbide drill bit.
- c) Carefully drill pilot hole through porcelain/enamel and base metal using carbide type pilot drill.

*IMPORTANT: Always operate drill with light pressure at slow speed (300-400 rpm).*

- d) Insert pilot tip of spring-loaded porcelain cutter into pilot hole.
- e) Drill porcelain/enamel using spring-loaded porcelain cutter, making certain a complete ring has been cut through the porcelain/enamel to the metal base.
- f) Change to the metal cutter. With slow speed and light pressure, cut away the inner porcelain/enamel disc down to base metal. Make certain that the cutter does not touch outer rim of the cut porcelain/enamel. Continue with this bit to cut through metal until sink has been completely penetrated.

*IMPORTANT: When using a porcelain cutter it is critical to take precautions that it is always in a sharpened condition. Dull cutters are known to chip sinks.*

### **2. Mount the Faucet:**

- a) Familiarize yourself with all components shown in faucet diagram.
- b) Disassemble hardware from the threaded nipple, except for chrome base plate and rubber washer.

*NOTE: Rubber washer may be replaced with bead of plumber's putty for neater appearance.*

- c) Connect length of standard 1/4" tubing to faucet. Ensure plastic insert is in tubing. Push on firmly until it seats.
- d) Feed the threaded nipple through sink/counter mounting hole and orient the faucet as discussed with the customer.
- e) From below sink/counter assemble the black plastic washer, star washer and hex nut on threaded nipple and tighten by hand.
- f) After rechecking faucet orientation, tighten hex nut (9/16" wrench or deep socket) until faucet feels secure.
- g) From above the sink make any minor orientation corrections by turning the faucet with a padded adjustable wrench.
- h) Install plastic ferrule and compression nut on tubing.

*Note: Flats on chrome faucet may be used for tightening with an adjustable wrench. Use care not to mar chrome finish.*

### **B. Install the Feed Water Valve and Tubing**

The feed water valve supplied is designed for use with typical cold water shutoff valves with flexible hose connection to the faucet. Other hardware may be required for a different cold water supply configuration.

#### **Feed Water Valve Installation**



*NOTE: For basement installations the existing feed water tubing may have to be longer to reach feed valve.*

### C. Automatic Water Meter

Apply Teflon tape to threads on the INLET of the water meter and screw the inlet of the meter into the OUTLET of the filter housing. Meter should be tightened enough so that there are no leaks and the meter is facing the front of the DSF-PFOA housing assembly. This will allow for ease of setting the meter in gallons.

#### Tube installation

- 1) Insert free end of feed water tubing into the 1/4" fitting on the water meter.
- 2) Insert the tubing into the fitting on the faucet.

### D. Setting the Shut-off Meter

Turn the setting dial of the water meter clockwise so that the arrow points to the 1900 gallons mark. After the number of gallons is exhausted the automatic shut-off meter will cut the OUTLET flow of water and no more water will be allowed to pass through the system until the cartridge is changed and the meter reset. See "Changing Filter" for filter replacement procedure.

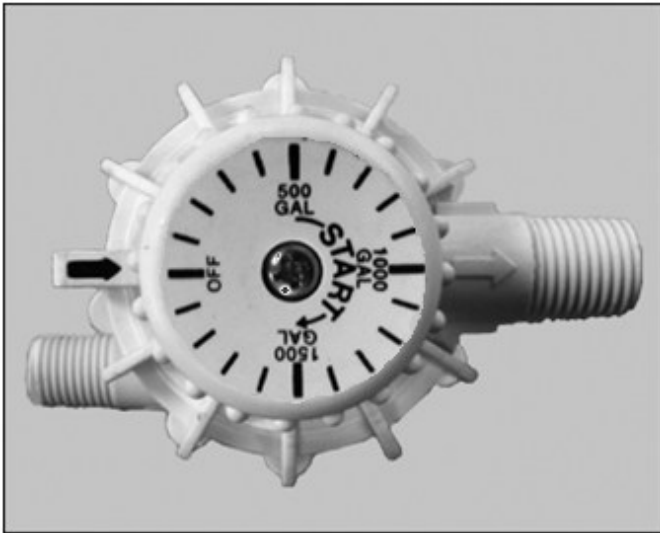

### E. Make Final Tubing Connections

With all of the components in place, the final tubing connections can be made. When routing tubing between components, several guidelines should be observed.

- Tubing runs should generally follow the contour of the cabinets rather than interfere with the cabinet storage area.
- Strive for neatness and an orderly tubing "flow" using fasteners (e.g. insulated staples) to secure the tubing. Cut tubing to the desired length.

- Arrange the tubing so there are no sharp bends and leave some "play" in the tubing for ease of servicing.
- Try to keep the tubing from the purification assembly to the tank and faucet as short as practical for good flow.

### F. Install Ice Maker Hookup (optional)

*Note: Check with refrigerator manufacturer for compatibility with your refrigerator model.*

The DSF-PFOA drinking water appliance can be connected to any standard refrigerator ice maker or ice maker/water dispenser. It should never be connected to a commercial type bar ice maker.

Hooking up an ice maker involves connecting a tee with shut off valve into the faucet tubing and routing tubing over to the refrigerator.

Before turning off the existing tap water supply to a refrigerator ice maker, always shut off the ice maker first (usually by lifting the lever arm above the bin to the upper most position). The ice maker should only be turned on again after 2-3 gallons are flushed through the DSF-PFOA system.

*NOTE: Before any service is performed on the DSF-PFOA system, always turn off ice maker valve and the ice maker unit. Only turn on when system is operating.*

### G. Start up the System

- 1) Double check that all connections are secure.
- 2) Turn on feed water valve and check for leaks. If any leaks are noted, turn off valve and correct before proceeding.
- 3) Turn on ball valve and open faucet until a steady stream of water flows. Close faucet, wait at least 5 minutes and carefully check for leaks. Correct as necessary.

### H. Flush System and Check Operation

- 1) Lift faucet handle and allow DSF-PFOA system to flush a minimum of 2-3 gallons down the drain or flush system until water runs clear. The flushed water should be discarded.

## SECTION V. OPERATION & MAINTENANCE

### A. Changing Filter

**NOTE: THIS DSF-PFOA SYSTEM CONTAINS FILTERS WHICH MUST BE REPLACED AT REGULAR INTERVALS TO MAINTAIN PROPER PERFORMANCE. USE ONLY FACTORY APPROVED FILTERS.**

Please see Page 3 for the recommended interval for changing the filters. Local conditions may dictate more frequent changes.

**NOTE: The system should be sanitized before installing the replacement cartridge.**

Use a drip pan to catch any water that may spill when the filter housings are removed:

- 1) Close the Ball Valve on the INLET of the housing and push the red button on top of the housing to relieve the operating pressure.
- 2) Loosen and remove the Filter Housing with the provided wrench. Discard the cartridge. **NOTE:** Exhausted filter cartridge may be disposed by normal means. Dispose as nonhazardous solid waste.
- 3) Wash the inside of the Housing(s) using a mild detergent and a soft cloth. Do not use abrasive cleaners or pads. Thoroughly rinse all soap from the housing before reassembly.
- 4) To sanitize the system and replace the filter cartridge(s):
  - a) Use a good quality unscented 5-1/4% liquid bleach.
  - b) Add one cap full of bleach (this is 2 tsp. or 10 ml) to the filter housing.
  - c) Turn the water meter to any number of gallons to allow for water flow.
  - d) The dispensing faucet should be open, slowly open the ball valve on the feed water line. As soon as water begins to drip out of the dispensing faucet, close the faucet.
  - e) Let the system stand for 15 minutes.
  - f) At the end of the 15 minutes, in the following order, open the ball valve; open the dispensing faucet to allow purging of the chlorine to the drain.

- g) Reset the automatic shut-off meter to the number of gallons recommended on page 3.
  - h) As soon as water begins to drip out of the dispensing faucet, close the faucet.
  - i) Let the system stand for 15 minutes.
  - j) At the end of the 15 minutes, in the following order, open the ball valve; open the dispensing faucet to allow purging of the chlorine to the drain.
- 5) Install new filters and reseal the system
  - 6) Flush a minimum of 2-3 gallons down the drain or flush system until water runs clear. The flushed water should be discarded.



B. Exploded Diagram

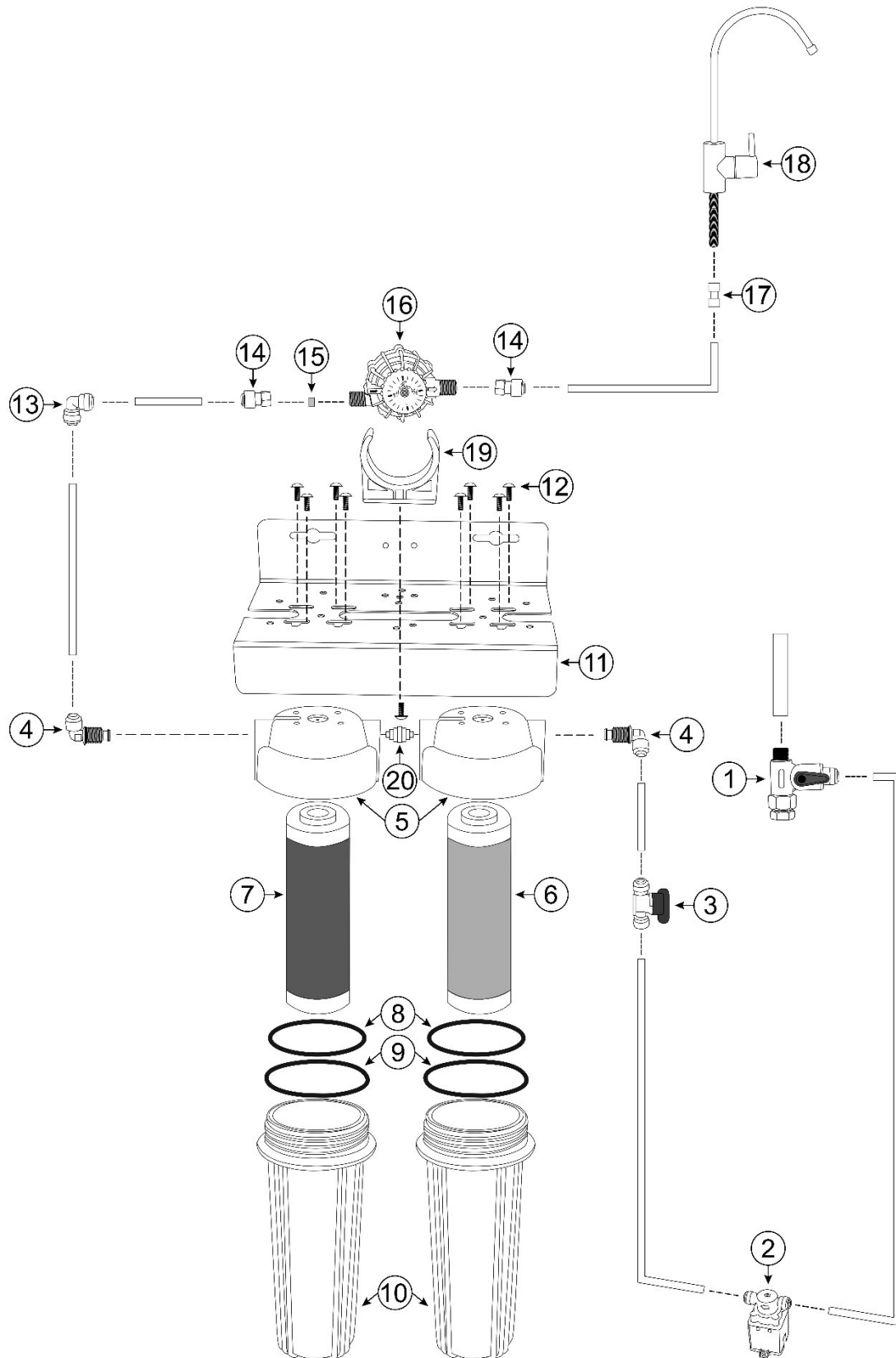

## PFA's Parts List

REF#	Part #	Description
1	RO-FWV	Feed Water Valve, 3/8"Mx1/2"Fx1/4"Tube, w/1/2"Mx3/8"F Adapt.
2	RO-LSV	Leak Stop Valve for RO System
3	BV-101	Ball Valve, 1/4" tube x 1/4" tube
4	4ME4-1	Male Elbow, 1/4" Tube x 1/4" M
5	W905-WF14	10" SLIM 905 HSG, WHITE SUMP
6	AF-10-3612	2.5" x 10" PFOA Reduction Cart
7	CB1005	High Flow Carbon Block, 2.5" x 10"
8	RO-TOR	Top O-Ring for RO Systems
9	RO-BOR	Bottom O-Ring for RO Systems
10	W905-WF14	10" SLIM 905 HSG, WHITE SUMP
11	BR-102N-WC	STEEL DOUBLE SUMP BRACKET
12	SCR10075-SS-A	Sump Screw 410SS
13	4UE4	UNION ELBOW, 1/4" TUBE X 1/4"
14	4FC4-NPT	Female Connector, 1/4" tube x 1/4" F NPT
15	MR03	0.5 gpm 3/4" flow control
16	ASO-14	Automatic Shut-Off, 1800 gallons
17	4FC4	Faucet Connector, 1/4" tube x 7/16" UNF thread
18	RO-DW-2	Luxury Long Reach Faucet, Non-Air Gap, Brushed Nickel
19	MC-25W-1	2-1/2" MEMBRANE HOUSING CLIP White
20	CC-2W-2	Threaded Dual Sump Connector With O-rings
21 (not shown)	TU-2W	1/4" OD White Poly Tubing, per foot

### C. Quick Connect Fittings

Your new DSF-PFOA Drinking Water Appliance is outfitted with new generation of user-friendly quick connect push-in fittings. Proper use of the fittings is shown in the diagrams.

It is important that the tubing selected for use with these connectors be of high-quality exact size and roundness, and with no surface nicks or scratches. If it is necessary to cut the tubing, use a plastic tubing cutter or sharp razor knife. Make a clean, square cut.

An optional blue locking clip is installed in certain fittings to provide extra security. Remove this clip first before trying to remove tubing by sliding away from fitting.

Should a leak occur at a fitting, the cause is usually defective tubing.

To fix:

- Relieve pressure
- Release tubing
- Cut off at least ¼" from end
- Reattach tubing
- Confirm connection is leak free

### TO ATTACH TUBING...

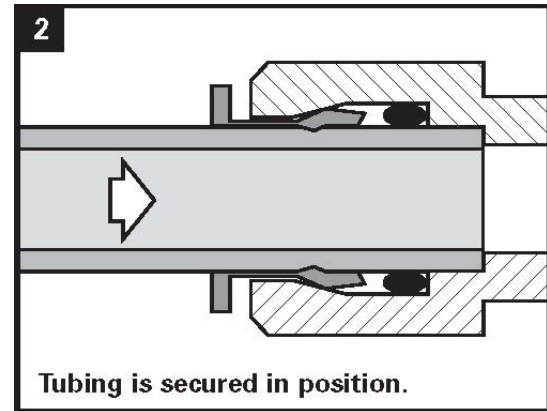
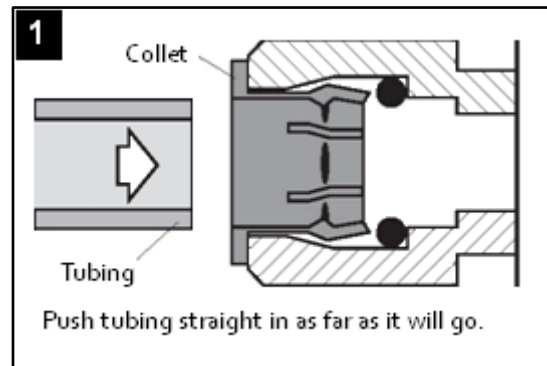

### TO RELEASE TUBING...

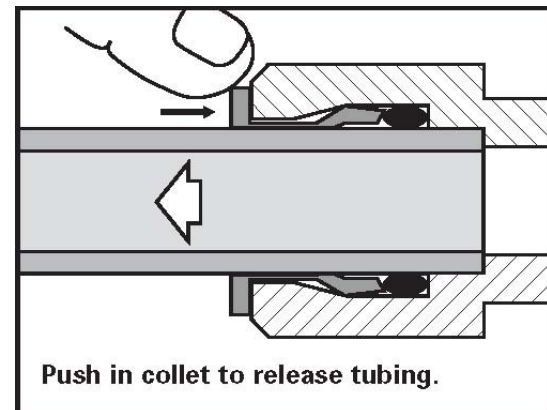

## SECTION VI. TROUBLE SHOOTING GUIDE

<b>Problem</b>	<b>Possible Cause</b>	<b>Solution</b>
<b>Low quantity of Product Water from Treatment System or Low Pressure at the Dispensing Faucet</b>	Feed Water Valve is plugged or closed.	Open Valve or unclog.
	Flow Control is plugged.	Replace Flow control or unclog.
	Clogged filter.	Replace filter.
	Low water pressure	Feed Water pressure must be at or above 40 psi.
	The Shut-off Meter reads "0"	Replace filter cartridge and reset shut-off meter.
	The INLET ball valve is closed.	Open valve.
<b>PFA's contaminant level exceeds EPA MCL</b>	Influent water quality pre-requisites have not been met.	Install required pre-treatment equipment.
	AF-10-3612 cartridge capacity has been exhausted.	Replace the cartridge.
<b>Faucet leaks or drips</b>	Leaks from base of the delivery tube or drips from spout.	Replace the faucet.
<b>Fitting leaks in general</b>	Close the Feed Water Valve or ball valve and relieve pressure before disconnecting any tubing or replacing any fitting. Before replacing a fitting, re-cut the tubing and re-insert into the fitting to see if that solves the leak. If pipe threads are leaking, remove and check O-rings for damage.	

## Leak Stop Valve – Compressed Pellet Replacement

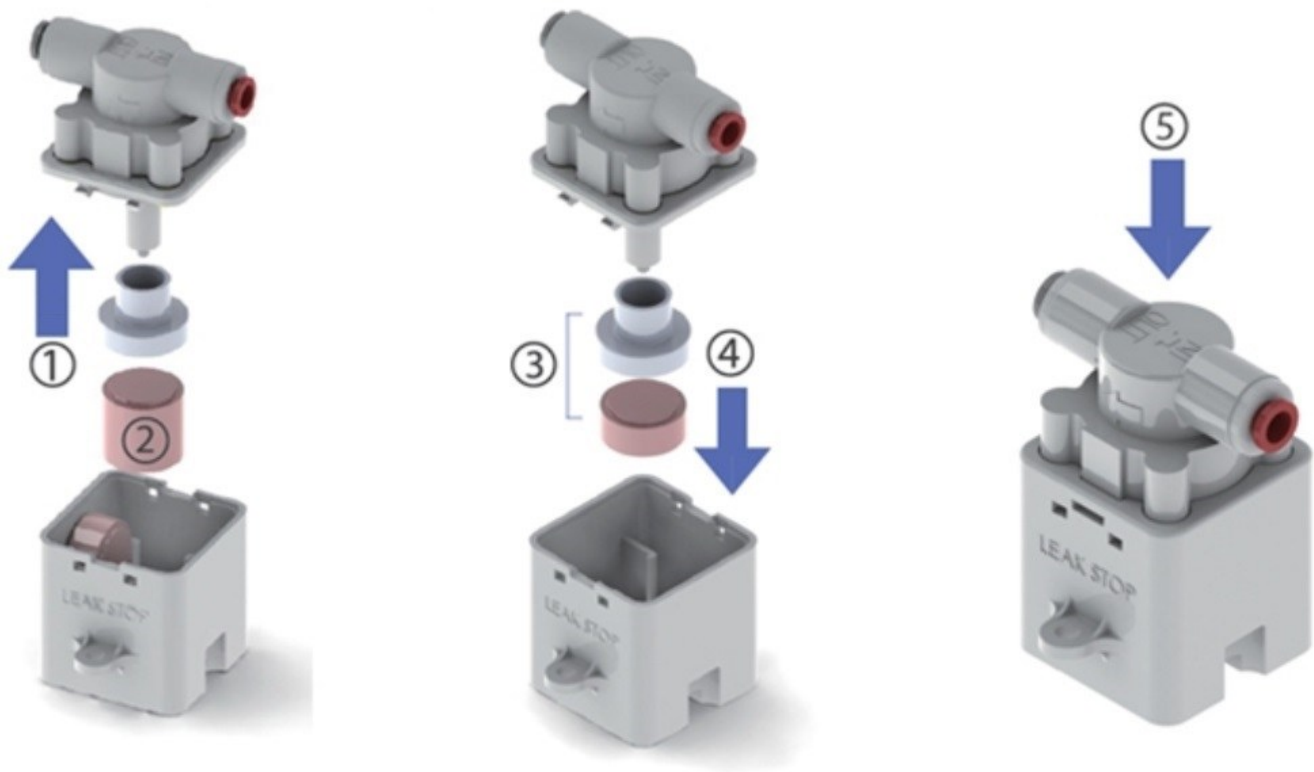

- 1) Pull the upper cover upward and separate it from the lower body.
- 2) Remove the expanded pellet from the retainer.
- 3) Replace the expanded pellet with the spare compressed pellet.
- 4) Seat the compressed pellet and retainer into the lower body.
- 5) Push the upper cover down until it snaps securely in place.



## **PFA'S DRINKING WATER SYSTEM LIMITED WARRANTY**

### ***What Does This Warranty Cover?***

*This warranty covers any defects in materials and workmanship of the PFA's Drinking Water System when installed and operated within recommended parameters, with the exceptions stated below.*

### ***How Long Does The Coverage Last?***

*The manufacturer will warrant its PFA's Drinking Water System, for a period of one year from the date of purchase. All implied warranties including merchantability and fitness for a particular purpose are limited to one year from the date of purchase for the PFA's Drinking Water System. Some states do not allow limitations on how long an implied warranty lasts, so the above limitations may not apply to you.*

### ***What Will The Manufacturer Do?***

*The manufacturer will repair or replace at its discretion any defective component. You must pay any labor charges. You must also pay for shipping or travel charges to return the defective part(s).*

### ***What Does This Warranty Not Cover?***

*The above warranty will not apply to any part of the PFA's Drinking Water System that is damaged because of neglect, misuse, alterations, accident, misapplication, physical damage, or damage caused by fire, acts of God, freezing or hot waters or similar causes. Consequential and incidental damages are not recoverable under this warranty. Some states do not allow the exclusion or limitation of incidental or consequential damages, so the above limitation or exclusion may not apply to you.*

*We recommend that you use only the manufacturer's replacement parts since improper parts or incorrectly performed maintenance or repair voids this warranty.*

### ***How Do You Get Service?***

*In order to be eligible for service under this warranty you must (a) contact your local dealer who supplied the unit.*

### ***How Does State Law Apply?***

*This warranty gives you specific legal rights and you may also have other rights which vary from state to state.*