

# STERLING

---

## WATER TREATMENT

### INSTALLATION MANUAL

### CRS-3



---

# STERLING

---

## WATER TREATMENT

12630 US 33 N.  
Churubusco, IN 46723  
Ph. (260)693-1972 Fax (260)693-0602  
[www.sterlingwatertreatment.com](http://www.sterlingwatertreatment.com)

# TABLE OF CONTENTS:

<b>SECTION I.</b>	<b>INTRODUCTION.....</b>	<b>2</b>
<b>SECTION II.</b>	<b>SPECIFICATIONS.....</b>	<b>2</b>
<b>SECTION III:</b>	<b>PREPARATION.....</b>	<b>3</b>
	<i>A. Major System Components.....</i>	<i>3</i>
	<i>B. Tools Recommended for Installation.....</i>	<i>3</i>
	<i>C. Determine System Location.....</i>	<i>3</i>
	<i>D. Prepare the Area for Installation.....</i>	<i>4</i>
	<i>E. Prepare the Appliance for Installation.....</i>	<i>4</i>
<b>SECTION IV.</b>	<b>INSTALLATION STEPS.....</b>	<b>4</b>
	<i>A. Install the Faucet.....</i>	<i>4</i>
	1. Make the Faucet Mounting Hole.....	4
	2. Mount the Faucet.....	5
	<i>B. Install the Feed Water Valve and Tubing.....</i>	<i>5</i>
	<i>C. Make Initial Tubing Connections.....</i>	<i>6</i>
	<i>D. Install the Filter Assembly &amp; Leak Stop Valve.....</i>	<i>6</i>
	<i>E. Make Final Tubing Connections.....</i>	<i>6</i>
	<i>F. Start up the System.....</i>	<i>6</i>
	<i>G. Flush System of Particles and Check Operation.....</i>	<i>6</i>
<b>SECTION V: OPERATION &amp; MAINTENANCE.....</b>		<b>6</b>
	<i>A. Normal Operation.....</i>	<i>6</i>
	<i>B. Changing Filters.....</i>	<i>6</i>
	<i>C. Installation Drawing &amp; Parts List.....</i>	<i>7</i>
	<i>D. Quick Connect Fittings.....</i>	<i>8</i>
<b>SECTION VI: TROUBLESHOOTING GUIDE.....</b>		<b>9</b>
<b>Leak Stop Valve Compressed Pellet Replacement.....</b>		<b>10</b>
<b>LIMITED WARRANTY.....</b>		<b>11</b>

## SECTION I. INTRODUCTION

Congratulations, you have just purchased one of the finest Drinking Water Appliances available.

Like any other fine product, this appliance requires periodic maintenance in accordance with the schedule outlined below.

### Recommended Filter Change Schedule\*

1 - Pre-filter, QCF-S	6 Months
2 – Carbon Block Pre-filter for Chlorine Removal, QCF-CB	6 Months
3 – Ultra Filter Membrane, QCF-UF	6 Months

\*Based on standard conditions

**CARBON BLOCK PRE-FILTER** - The carbon filter is a carbon block that has coconut shell activated carbon with a smaller pore size to increase the range of organics removed and extend the amount of chlorine reduction. Carbon block filter has a five micron rating to further protect the membrane.

**ULTRA FILTRATION MEMBRANE** -The UF Membrane is the heart of the filtration system. It is designed to reduce particles, colloids, and macromolecules down to 0.03 microns. UF membranes have the capability of reducing bacteria, viruses, silt, and colloids. UF membranes are not recommended on using with biologically unsafe water.

Your new Drinking Water system uses a combination of ultra filtration technologies to reduce unwanted contaminants in a water supply. The following steps combine to give you the best in clear sparkling drinking water:

**MECHANICAL FILTRATION** - The sediment pre-filter will remove the larger particles such as silt, rust and scale. Its 5 micron (equal to 0.0002 inch) nominal rating helps to give maximum life to the UF Membrane and carbon filter.

## SECTION II. SPECIFICATIONS

### TABLE A – QUALIFIED SYSTEM PERFORMANCE

Because the performance of an UF Membrane is highly dependent upon pressure, temperature and TDS, the following should be used for comparison purposes only.

	U.S.	Metric
Membrane Production <sup>1</sup>	5,000 gallons	18,927 Liters

<sup>1</sup> Industry standards measure UF Membranes performance with no backpressure on the product water, at 65 psig (448kPa) and 77°F (25°C). The production rate of a new Membrane can decrease by 10% per year or more, depending upon the scaling and fouling tendencies of the Feed Water.

**TABLE B – RECOMMENDED OPERATING LIMITS FOR FEED WATER**

<b>Specifications</b>	<b>UF Membrane</b>
Water Pressure	40-100 psig
TDS	2000 ppm (also mg/l) max.
Temperature	40-100°F
pH	4-11 (optimum rejection at pH 7.0 – 7.5)
Turbidity	300 NTU
Chlorine	200 mg/l max.
Bacteria	Must be potable**

**\*\*DO NOT USE WITH WATER THAT IS MICROBIOLOGICALLY UNSAFE OR OF UNKNOWN QUALITY.**

## **SECTION III: PREPARATION**

### *A. Major System Components*

The following components comprise the CRS-3 Drinking Water System:

1. A filter assembly consisting of the aluminum bracket, filter housings and shut-off valve.
2. A faucet kit.
3. A plastic tubing kit with feed water valve, drain saddle and leak stop valve.
4. Other items necessary for installation may include wood screws or machine screws for mounting the filter assembly. Concrete anchors may be required for hanging on basement wall, additional tubing or tube connectors, and plastic wire ties for organizing tubing.

Note: For systems equipped with Quick Connect fittings, see page 9.

### *B. Tools Recommended for Installation*

The following tools will cover most of the installation sites encountered:

- 3/8" variable speed electric drill.
- Extension work light with outlet.
- Safety Glasses.
- 1-1/4" porcelain hole cutter kit.
- 1-1/4" Greenlee hole punch and 1/8" and 1/2" metal drill bits for pilot hole.
- Center punch and hammer.
- 1-1/4" wood bit.
- Assorted wood and metal drill bits including 7/32" metal drill bit.
- Phillips head and flat blade screwdrivers.
- 1/2", 9/16" and 5/8" open end wrench.

- 10" Crescent wrench with jaws taped to hold faucet.
- Teflon tape.
- Wide masking tape or duct tape.
- Plastic tubing cutter.
- Extra plastic tubing.

### *C. Determine System Location*

The CRS-3 system can be located under a sink or in a basement depending on space availability and the customer's preference. If a basement installation is selected, additional tubing, hardware and fittings may be needed and a hole will have to be made from inside the cabinet, through the floor, to the basement. Never install in an area of the home where temperature is freezing as damage to the system will result.

- 1) Faucet - The faucet should be placed near the sink where drinking water is normally obtained. Convenience of use (filling of water pitchers and glasses), and an open area beneath the faucet under the sink for attaching product tubing are considerations. A 2" diameter flat surface is required above and below the mounting site. The thickness of the mounting surface should not exceed 1-1/4". Watch for strengthening webbing on the underside of cast iron sinks.
- 2) Filter Assembly - The assembly may be mounted on either the right or left side of the under-sink area or a cabinet. Mounting in the basement is also an option near a laundry or utility sink where cold potable water is accessible. The mounting location should allow adequate clearance and accessibility for cartridge changes.
- 3) Feed Water Connection - The feed water shut off valve should be located as close to the assembly as possible. **ONLY USE A POTABLE COLD WATER SUPPLY.**

Softened water is preferred as it will extend the life of the UF Membrane.

- 4) Leak Stop Valve – Drinking water systems inherently have many connections which could leak. It is necessary to install the included Leak Stop Valve very close to and/or under the filter assembly. It must be fastened to the floor or cabinet base with screws or double-sided tape. The feed water supply must pass through the Leak Stop Valve (See page 7). Should a leak occur and the underside of the Leak Stop Valve gets wet, the feed water will be terminated. Once activated, the Leak Stop Valve can be reset one time (See page 10).

#### D. Prepare the Area for Installation

Clear objects from under the sink prior to installation. Arrange a light for the work area, if necessary.

If a basement installation is called for, determine where components will be located and how they will be mounted. Special mounting brackets and hardware may be necessary to secure the system to a wall or ceiling joists.

Inspect cold water supply line to determine if any special fittings, in addition to what is included in the kit, are required.

#### E. Prepare the Appliance for Installation

Open shipping carton and remove components. Check that all installation parts are present which includes the filter assembly, faucet, installation hardware, and tubing.

## SECTION IV. INSTALLATION STEPS

All plumbing should be done in accordance with state and local plumbing codes.

**NOTE:** Some codes may require installation by a licensed plumber; check with the local plumbing authority prior to installation.

In restricted under-sink areas, it may be easier to install the faucet first. Allow adequate tubing lengths for any final component position.

#### A. Install the Faucet

**See Figure 1 for Faucet Installation Diagram**

The faucet should be positioned so that it empties into the sink and the spout swivels freely for convenience. If the sink already has a hole provided that can accommodate the faucet, then no drilling is required and you can proceed to the section on mounting the faucet.

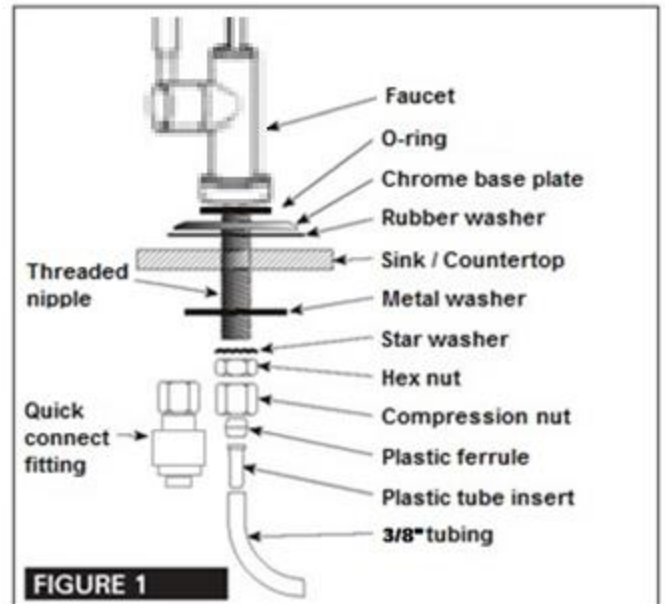

#### 1. Make the Faucet Mounting Hole

**IMPORTANT:** It is mandatory that safety glasses be worn during sink hole drilling operations to prevent eye injury.

Before starting the hole making operation, always check below the sink so that nothing interferes with mounting the faucet such as reinforcing ribs, support brackets or cabinet construction.

#### STAINLESS STEEL SINK:

Recommended tools:

- Center punch
- Variable speed drill and high speed drill bits.
- Greenlee chassis punch 7/8" hole size (alternate 9/16" size may be used for non air gap faucet)
- Protective gloves

Procedure:

- a) Center punch a small indent at the desired faucet location.
- b) Slowly drill the required pilot hole for the chassis punch.

- c) Set up the chassis punch per instructions and tighten nut to cut the desired hole size.
- d) Clean up sharp edges with a file if necessary.

## **PORCELAIN/ENAMEL/CERAMIC ON SHEET METAL OR CAST IRON BASE:**

Recommended tools:

- Variable speed drill
- Relton porcelain cutter tool set 7/8" size (alternate 9/16: size may be used for air gap or non-air gap faucet)
- Plumber's putty

It is important to understand what is involved in this procedure. First, the glassy layer of porcelain must be penetrated through to the base metal. Second, a center disc of porcelain must be removed while protecting the surrounding porcelain against chip ping or fracturing. Third, the base metal must be drilled through to complete the hole.

Procedure:

- a) Mark the center for the 7/8" hole
- b) Form shallow putty dam around hole area and fill with enough water to lubricate carbide drill bit.
- c) Carefully drill pilot hole through porcelain/enamel and base metal using carbide type pilot drill.

*IMPORTANT: Always operate drill with light pressure at slow speed (300-400 rpm).*

- d) Insert pilot tip of spring-loaded porcelain cutter into pilot hole.
- e) Drill porcelain/enamel using spring-loaded porcelain cutter, making certain a complete ring has been cut through the porcelain/enamel to the metal base.
- f) Change to the metal cutter. With slow speed and light pressure, cut away the inner porcelain/enamel disc down to base metal. Make certain that the cutter does not touch outer rim of the cut porcelain/enamel. Continue with this bit to cut through metal until sink has been completely penetrated.

*IMPORTANT: When using a porcelain cutter it is critical to take precautions that it is always in a sharpened condition. Dull cutters are known to chip sinks.*

## **2. Mount the Faucet:**

- a) Familiarize yourself with all components shown in faucet diagram.
- b) Disassemble hardware from the threaded nipple, except for chrome base plate and rubber washer.

*NOTE: Rubber washer may be replaced with bead of plumber's putty for neater appearance.*

- c) Connect length of standard 1/4" tubing to faucet. Ensure plastic insert is in tubing. Push on firmly until it seats.
- d) Feed the threaded nipple through sink/counter mounting hole and orient the faucet as discussed with the customer.
- e) From below sink/counter assemble the black plastic washer, star washer and hex nut on threaded nipple and tighten by hand.
- f) After rechecking faucet orientation, tighten hex nut (9/16" wrench or deep socket) until faucet feels secure.
- g) From above the sink make any minor orientation corrections by turning the faucet with a padded adjustable wrench.
- h) Install plastic ferrule and compression nut on tubing.

*Note: Flats on chrome faucet may be used for tightening with an adjustable wrench. Use care not to mar chrome finish.*

## **B. Install the Feed Water Valve and Tubing**

The feed water valve supplied is designed for use with typical cold water shutoff valves with flexible hose connection to the faucet. Other hardware may be required for a different cold water supply configuration.

### **Feed Water Valve Installed**



*NOTE: For basement installations the existing feed water tubing may have to be longer to reach feed valve.*

### *C. Make Initial Tubing Connections*

It is advantageous to make some of the tubing connections at this time, since the under-sink work area is not so cramped and access to the components is easier.

### *D. Install Filter Assembly & Leak Stop Valve*

The filter assembly is usually mounted to the right or left sink cabinet sidewall, taking into consideration the space available. Generally, the filter assembly is positioned toward the front for accessibility during cartridge changes.

To mount the filter assembly elevate at least 2" off the cabinet floor and, while keeping level, mark the location of the mounting holes on cabinet sidewall. Make small pilot holes with an awl or drill and screw in the two mounting screws, leaving just enough protruding to allow bracket mounting slots to slide over them.

*NOTE: If the cabinet sidewalls are not of solid construction, the filter assembly can be set on the cabinet floor and held against the sidewall with the mounting screws.*

Securely mount the Leak Stop Valve to the base of the cabinet below the filter assembly. See III. C. 4. on page 4 and exploded diagram on page 7.

### *E. Make Final Tubing Connections*

With all of the components in place, the final tubing connections can be made. When routing tubing between components, several guidelines should be observed.

- Tubing runs should generally follow the contour of the cabinets rather than interfere with the cabinet storage area.
- Strive for neatness and an orderly tubing "flow" using fasteners (e.g. insulated staples) to secure the tubing. Cut tubing to the desired length.
- Arrange the tubing so there are no sharp bends and leave some "play" in the tubing for ease of servicing.
- Try to keep the tubing from the purification assembly to the faucet as short as possible.

### *F. Start up the System*

- 1) Double check that all connections are secure.
- 2) Turn on feed water valve and check for leaks. If any leaks are noted, turn off valve and correct before proceeding.
- 3) Open faucet until a steady stream of water flows. Close faucet, wait at least 5 minutes and carefully check for leaks. Correct as necessary.

### *G. Flush System of Particles and Check Operation*

- 1) Lift faucet handle and allow system to pass a few gallons of water. Run water from faucet until it flows clear. Once water runs clear, it should be ready to drink.

## **SECTION V. OPERATION & MAINTENANCE**

### *A. Normal Operation*

- 1) It is normal for the water to flow at a rate of 1 gpm.

### *B. Changing Filter*

*NOTE: THE CRS-3 SYSTEM CONTAINS FILTERS WHICH MUST BE REPLACED AT REGULAR INTERVALS TO MAINTAIN PROPER PERFORMANCE. USE ONLY FACTORY APPROVED FILTERS.*

Please see Page 3 for the recommended interval for changing the filters. Local conditions may dictate more frequent changes.

Use a drip pan to catch any water that may spill when the filter housings are removed:

- 1) Close plastic supply valve located on the inlet line of the system.
- 2) Open the faucet and wait for the flow to stop.
- 3) The cartridges can be hinged out away from the wall. Rotate the cartridge 1/4 turn counter clockwise and pull down. The cartridges can be disposed.
- 4) Push the new filter into the head and rotate it clockwise ¼ turn.
- 5) Wipe up any spilled water.

C. Installation Drawing & Parts List

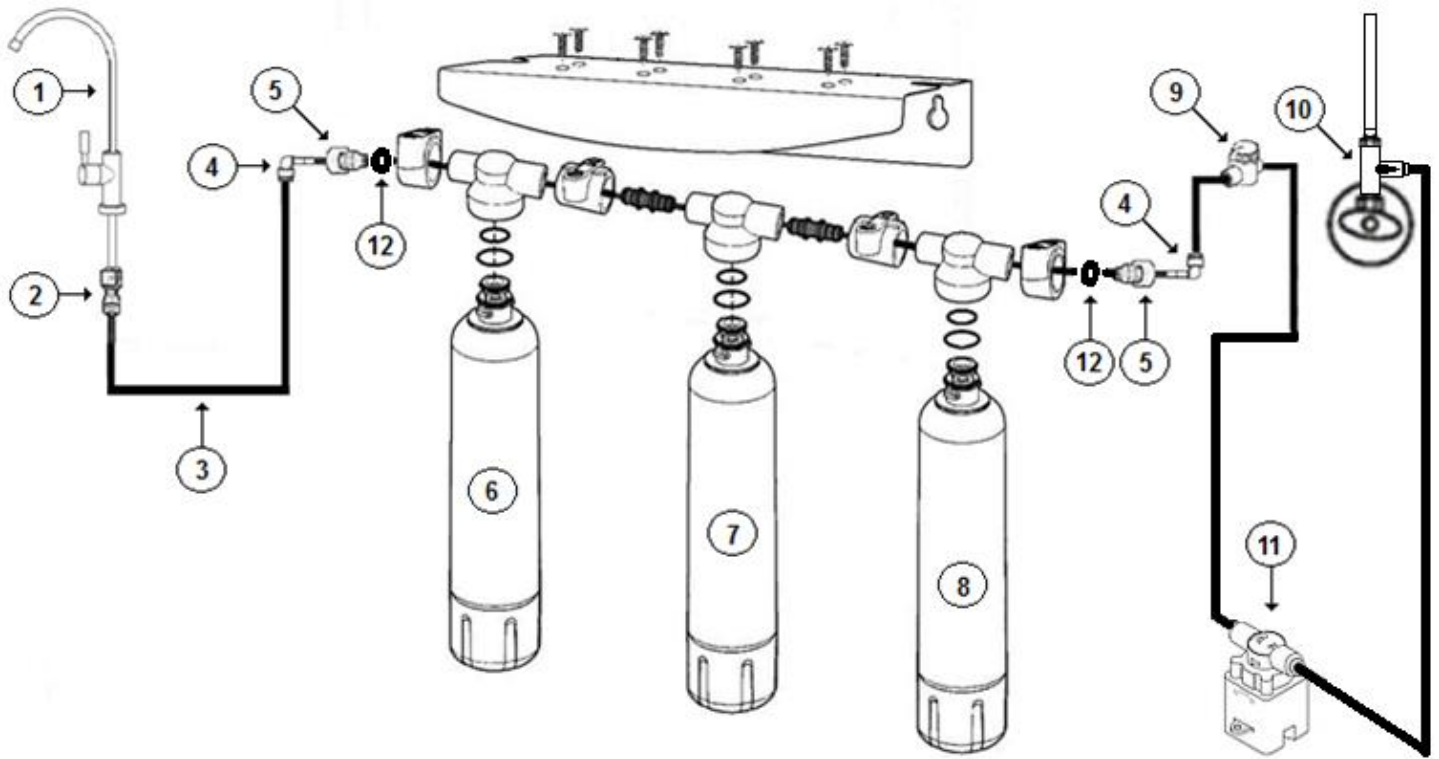

Ref	Part Number	Description
1	RO-DW-1	Luxury long reach faucet, non air gap, chrome
2	4FC4	Faucet connector, 1/4" tube X 7/16" UNF
3	TU-2W	1/4" OD white poly tubing, per foot
4	4SE4	Stem elbow, 1/4" tube X 1/4" stem
5	4MC	Male connector, 1/4" tube X 1/4" MNPT
6	QCF-UF	Quick-Change Filter, UF Membrane
7	QCF-CB	Quick-Change Filter, Carbon Block
8	QCF-S	Quick-Change Filter, Sediment
9	BV-101	Ball valve, 1/4" tube X 1/4" tube
10	RO-FWV	Feed water valve, 3/8" MNPT x 1/2" FNPT x 1/4" tube w/ 1/2" MNPT x 3/8" FNPT adapter
11	RO-LSV	Leak Stop Valve
12	RO-GSK14	Gasket, 1/4" fitting



### D. Quick Connect Fittings

Your new CRS-3 Drinking Water Appliance is equipped with user-friendly quick connect push-in fittings. Proper use of the fittings is shown in the diagrams.

It is important that the tubing selected for use with these connectors be of high quality exact size and roundness, and with no surface nicks or scratches. If it is necessary to cut the tubing, use a plastic tubing cutter or sharp razor knife. Make a clean, square cut.

An optional blue locking clip is installed in certain fittings to provide extra security. Remove this clip first before trying to remove tubing by sliding away from fitting.

Should a leak occur at a fitting, the cause is usually defective tubing.

To fix:

- Relieve pressure
- Release tubing
- Cut off at least ¼" from end
- Reattach tubing
- Confirm connection is leak free

### TO ATTACH TUBING...

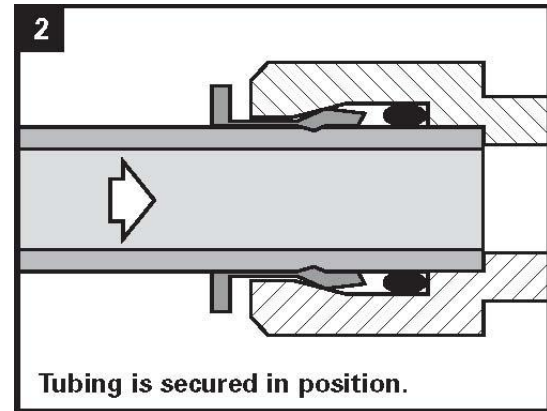
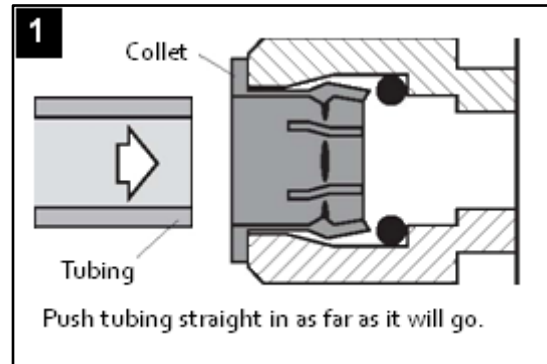

### TO RELEASE TUBING...

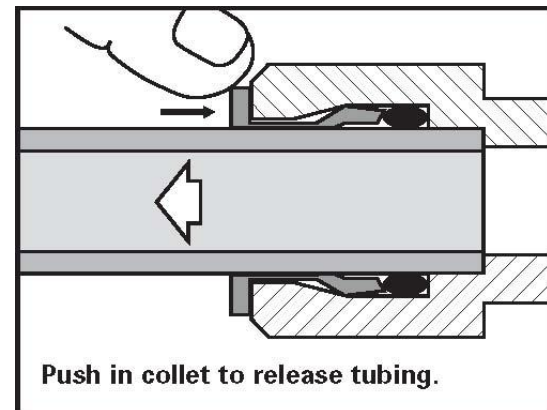

## SECTION VI. TROUBLE SHOOTING GUIDE

<b>Problem</b>	<b>Possible Cause</b>	<b>Solution</b>
<b>Low quantity of Product Water from Dispensing Faucet</b>	Feed Water Saddle Valve is plugged or closed.	Open Valve or unclog.
	Clogged Sediment Prefilter or Activated Carbon Prefilter.	Replace filters.
	Low water pressure	Feed Water pressure must be above 40 psig.
<b>Low pressure at the Dispensing Faucet</b>	The Dispensing Faucet is out of adjustment or faulty.	Repair or replace Dispensing Faucet.
	Clogged Sediment Prefilter or Activated Carbon Prefilter.	Replace Filters.

<b>Problem</b>	<b>Possible Cause</b>	<b>Solution</b>
<b>Tastes and odors in the Product Water</b>	The Activated Carbon Prefilter is exhausted.	Replace Filters.
	Dissolved gasses in the Feed Water.	Pretreat Feed Water to remove dissolved gasses.
<b>Faucet leaks or drips</b>	Leaks from base of the delivery tube.	O-ring is bad, replace O-ring.
<b>Fitting leaks in general</b>	Close the Feed Water Saddle Valve and relieve pressure before disconnecting any tubing or replacing any fitting. Before replacing a fitting, re-cut the tubing and re-insert into the fitting to see if that solves the leak. If pipe threads are leaking, remove and retape with Teflon tape.	

## Leak Stop Valve – Compressed Pellet Replacement

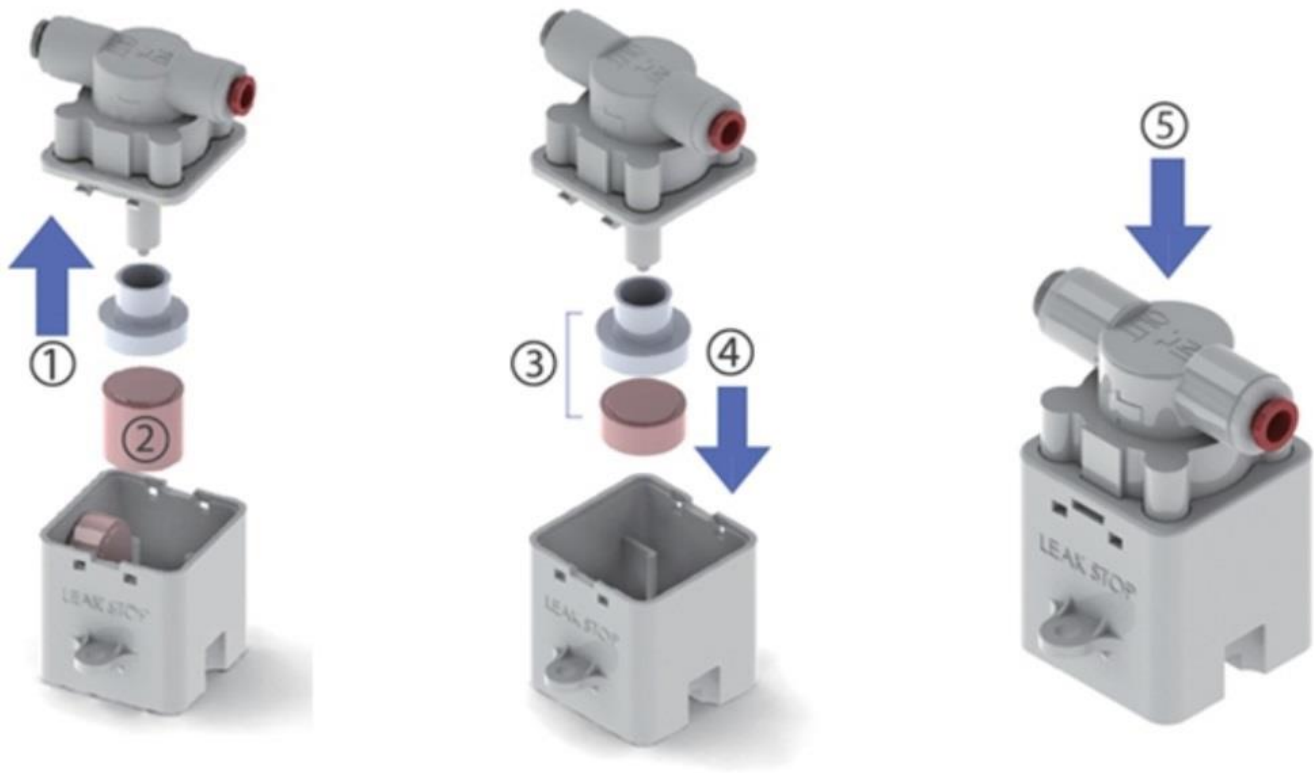

- 1) Pull the upper cover upward and separate it from the lower body.
- 2) Remove the expanded pellet from the retainer.
- 3) Replace the expanded pellet with the spare compressed pellet.
- 4) Seat the compressed pellet and retainer into the lower body.
- 5) Push the upper cover down until it snaps securely in place.



## **CRS-3 DRINKING WATER SYSTEM LIMITED WARRANTY**

### **What Does This Warranty Cover?**

*This warranty covers any defects in materials and workmanship of the CRS-3 Drinking Water System when installed and operated within recommended parameters, with the exceptions stated below.*

### **How Long Does The Coverage Last?**

*The manufacturer will warrant its CRS-3 Drinking Water System, for a period of one year from the date of purchase. All implied warranties including merchantability and fitness for a particular purpose are limited to one year from the date of purchase for the CRS-3 Drinking Water System. Some states do not allow limitations on how long an implied warranty lasts, so the above limitations may not apply to you.*

### **What Will The Manufacturer Do?**

*The manufacturer will repair or replace at its discretion any defective component. You must pay any labor charges. You must also pay for shipping or travel charges to return the defective part(s).*

### **What Does This Warranty Not Cover?**

*This warranty does not cover the disposable sediment and carbon filters whose service life depends on feed water conditions. In addition, the membrane is only warranted if the required feed water conditions are met.*

*The above warranty will also not apply to any part of the CRS-3 Drinking Water System that is damaged because of neglect, misuse, alterations, accident, misapplication, physical damage, or damage caused by fire, acts of God, freezing or hot waters or similar causes. Consequential and incidental damages are not recoverable under this warranty. Some states do not allow the exclusion or limitation of incidental or consequential damages, so the above limitation or exclusion may not apply to you.*

*We recommend that you use only the manufacturer's replacement parts since improper parts or incorrectly performed maintenance or repair voids this warranty.*

### **How Do You Get Service?**

*In order to be eligible for service under this warranty you must (a) contact your local dealer who supplied the unit.*

### **How Does State Law Apply?**

*This warranty gives you specific legal rights and you may also have other rights which vary from state to state.*