

# STERLING

---

## WATER TREATMENT

### INSTALLATION MANUAL

#### QCRO-50



---

# STERLING

---

## WATER TREATMENT

12630 US 33 N.  
Churubusco, IN 46723  
Ph. (260)693-1972 Fax (260)693-0602  
[www.sterlingwatertreatment.com](http://www.sterlingwatertreatment.com)

# TABLE OF CONTENTS:

<b>SECTION I.</b>	<b>INTRODUCTION.....</b>	<b>3</b>
<b>SECTION II.</b>	<b>SPECIFICATIONS.....</b>	<b>3</b>
<b>SECTION III:</b>	<b>PREPARATION.....</b>	<b>4</b>
	<i>A. Major System Components.....</i>	<i>4</i>
	<i>B. Tools Recommended for Installation.....</i>	<i>4</i>
	<i>C. Determine System Location.....</i>	<i>4</i>
	<i>D. Prepare the Area for Installation.....</i>	<i>5</i>
	<i>E. Prepare the Appliance for Installation.....</i>	<i>5</i>
<b>SECTION IV.</b>	<b>INSTALLATION STEPS.....</b>	<b>5</b>
	<i>A. Install the Faucet.....</i>	<i>6</i>
	1. Make the Faucet Mounting Hole.....	6
	2. Mount the Faucet.....	7
	<i>B. Install the Feed Water Valve and Tubing.....</i>	<i>7</i>
	<i>C. Prefill and Sanitize the Storage Tank.....</i>	<i>7</i>
	<i>D. Install the Drain Connection.....</i>	<i>8</i>
	<i>E. Install the RO Membrane.....</i>	<i>8</i>
	<i>F. Make Initial Tubing Connections.....</i>	<i>9</i>
	<i>G. Install the Purification Assembly and Storage Assembly.....</i>	<i>9</i>
	<i>H. Make Final Tubing Connections.....</i>	<i>9</i>
	<i>I. Install Ice Maker Hookup (optional).....</i>	<i>9</i>
	<i>J. Start up the System.....</i>	<i>9</i>
	<i>K. Flush System of Preservative and Check Operation.....</i>	<i>9</i>
<b>SECTION V:</b>	<b>OPERATION &amp; MAINTENANCE.....</b>	<b>10</b>
	<i>A. Normal Operation.....</i>	<i>10</i>
	<i>B. Changing Filters.....</i>	<i>10</i>
	<i>C. For Systems Equipped with Quick Connect Fittings.....</i>	<i>12</i>
<b>SECTION VI:</b>	<b>TROUBLESHOOTING GUIDE.....</b>	<b>13</b>
<b>LIMITED WARRANTY.....</b>		<b>15</b>

## SECTION I. INTRODUCTION

Congratulations, you have just purchased one of the finest Reverse Osmosis Drinking Water Appliances available.

Like any other fine product, this appliance requires periodic maintenance in accordance with the schedule outlined below.

### Recommended Filter Change Schedule\*

1 - Pre-filter, QCF-S	6 Months
2 - Granulated Activated Carbon Pre-Filter, QCF-GAC	6 Months
3 - Carbon Pre-filter for Chlorine Removal, QCF-CB	6 Months
4 - Reverse Osmosis Membrane	24-36 Months
5 - Inline Carbon Post Filter, IC10Q	6 Months

\*Based on standard conditions

Your new Reverse Osmosis (R.O.) Drinking Water system uses a combination of filtration technologies to reduce unwanted contaminants in a water supply. The following steps combine to give you the best in clear sparkling drinking water:

**MECHANICAL FILTRATION** - The sediment pre-filter will remove the larger particles such as silt, rust and scale. Its 5 micron (equal to 0.0002 inch) nominal rating helps to give maximum life to the R.O. Membrane and carbon filter.

**ACTIVATED CARBON PRE FILTERS** - The first carbon filter contains granular activated carbon which removes chlorine and absorbs organics that can damage the membrane. The second carbon filter is a carbon block that has activated carbon with a smaller pore size to increase the range of organics removed and extend the amount of chlorine reduction. Carbon block filter has a five micron rating to further protect the membrane.

**REVERSE OSMOSIS MEMBRANE** -The R.O. Membrane is the heart of the filtration system. It is designed to reduce the dissolved mineral content of the water. Minerals picked up in the environment by the water are measured as Total Dissolved Solids (T.D.S.).In the Reverse Osmosis process, dissolved minerals are separated from the incoming water (Feed Water) to produce the product water (the Permeate). The excess minerals are rinsed to drain (the Reject Water). The spiral wound construction of the R.O. Membrane provides maximum surface area for water production and is less susceptible to fouling by particulate matter, turbidity and colloidal materials.

**ACTIVATED CARBON POST FILTER** - The Inline Carbon Post Filter cartridge contains carbon particles with a vast network of pores. The tremendous surface area of these pores (typically 800-1200 square meters per gram of carbon) gives the carbon very good adsorptive sites for chlorine as well as other substances that contribute to tastes and odors. The product water from the membrane as well as the holding tank passes through the Activated Carbon Post filter on the way to the Dispensing Faucet. The Activated Carbon Post Filter reduces tastes and odors that may pass through the system. It adds a final “polish” to the water.

## SECTION II. SPECIFICATIONS

### TABLE A – QUALIFIED SYSTEM PERFORMANCE

Because the performance of an R.O. Membrane is highly dependent upon pressure, temperature and TDS, the following should be used for comparison purposes only.

	U.S.	Metric
Membrane Production <sub>1</sub>	40-60 gpd	151-227 lpd
Membrane TDS Reduction <sub>1</sub>	93% minimum	93% minimum
Drain (reject water) Flow	3-5 x product flow	3-5 x product flow
Empty Storage Tank Precharge	5-7 psig air	35-48 kPa air

<sup>1</sup> Industry standards measure R.O. Membranes performance with no backpressure on the product water, at 65 psig (448kPa) and 77°F (25°C). Further conditions on the above are 600 ppm TDS. Production rate and TDS reduction figures are for a new Membrane that has been rinsed for 24 hours. The production rate of a new Membrane can decrease by 10% per year or more, depending upon the scaling and fouling tendencies of the Feed Water.

**TABLE B – RECOMMENDED OPERATING LIMITS FOR FEED WATER**

<b>Specifications</b>	<b>T.F.C. Membrane</b>
Water Pressure	40-100 psig (280-690 kPa)
TDS	2000 ppm (also mg/l) max.
Temperature	40-100°F (4-38°C)
pH	4-11 (optimum rejection at pH 7.0 – 7.5)
Hardness	Less than 7 gpg (120 mg/l) or soften
Iron	Less than 0.1 ppm (also mg/l)
Manganese	Less than 0.05 ppm (also mg/l)
Hydrogen Sulfide	None
Chlorine	See note
Bacteria	Must be potable**

**NOTE:** Chlorine will damage a T.F.C. Membrane. The Activated Carbon Prefilters have been designed to reduce chlorine from the incoming water. Change filters every 6 months, more often if the water contains more than 1 ppm chlorine.

**\*\*DO NOT USE WITH WATER THAT IS MICROBIOLOGICALLY UNSAFE OR OF UNKNOWN QUALITY.**

### SECTION III: PREPARATION

#### A. Major System Components

The following components comprise the R.O. Drinking Water System:

1. A Reverse Osmosis assembly consisting of the aluminum bracket, filter housings, automatic shut-off, membrane module and an in-line carbon filter.
2. A drinking water holding tank.
3. A faucet kit.
4. A plastic tubing kit with self-piercing saddle valve and drain clamp.
5. Other items necessary for installation may include wood screws or machine screws for mounting the R.O. assembly concrete anchors may be required for hanging on basement wall, additional tubing or tube connectors, and plastic wire ties for organizing tubing.

Note: For systems equipped with Quick Connect fittings, see page 11.

#### B. Tools Recommended for Installation

The following tools will cover most of the installation sites encountered:

- 3/8" variable speed electric drill.
- Extension work light with outlet.
- Safety Glasses.

- 1-1/4" porcelain hole cutter kit.
- 1-1/4" Greenlee hole punch and 1/8" and 1/2" metal drill bits for pilot hole.
- Center punch and hammer.
- 1-1/4" wood bit.
- Assorted wood and metal drill bits including 7/32" metal drill bit.
- Phillips head and flat blade screwdrivers.
- 1/2", 9/16" and 5/8" open end wrench.
- 10" Crescent wrench with jaws taped to hold faucet.
- Teflon tape.
- Wide masking tape or duct tape.
- Plastic tubing cutter.
- Extra plastic tubing.
- Low range air pressure gauge.
- Bicycle hand air pump.
- Small bottle of liquid chlorine bleach.

#### C. Determine System Location

The R.O. system can be located under a sink or in a basement depending on space availability and the customer's preference. If a basement installation is selected, additional tubing, hardware and fittings may be needed and a hole will have to be made from inside the cabinet, through the floor, to the basement. Never install in an area of the home where temperature is freezing as damage to the system will result.

Considerations for an ice maker or other remote hook up should be determined, including routing and any additional tools, fittings, and tubing that may be required.

- 1) **Faucet** - The faucet should be placed near the sink where drinking water is normally obtained. Convenience of use (filling of water pitchers and glasses), and an open area beneath the faucet under the sink for attaching product tubing are considerations. A 2" diameter flat surface is required above and below the mounting site. The thickness of the mounting surface should not exceed 1-1/4". Watch for strengthening webbing on the underside of cast iron sinks.
- 2) **Drinking Water Holding Tank** - The holding tank may be placed where it is convenient within 10 feet of the faucet. Under the sink or in an adjacent cabinet are best choices. If a longer run of tubing is required, the tubing should be 1/2" diameter O.D. size to prevent a high pressure drop. Remember, these tanks can weigh up to 30 pounds when full of water, a firm, and level area is required.
- 3) **R.O Assembly** - The R.O. Assembly may be mounted on either the right or left side of the under-sink area or a cabinet. Mounting in the basement is also an option, one possible location is near the laundry /utility sink where cold potable water and drain access is handy. The mounting location should allow adequate clearance and accessibility for cartridge changes.
- 4) **Feed Water Connection** - The self-piercing feed water shut off valve should be located as close to the R.O. assembly as possible. **USE A POTABLE COLD WATER SUPPLY ONLY.** Softened water is preferred as it will extend the life of the R.O. Membrane.
- 5) **Drain Connection** - The drain saddle assembly is designed to fit around a standard 1-1/2" OD drain pipe. The drain saddle should always be installed above (before) the trap and on the vertical or horizontal tail piece. Never install the drain saddle close to the outlet of a garbage disposal or plugging of the RO drain line may occur. If discharging into an utility sink or standpipe, an air gap of greater than 1" above the flood rim must be provided. Do NOT connect the system drain line to the dishwasher drain or near the garbage disposal.

#### *D. Prepare the Area for Installation*

To save time it is often advised to call the customer and request they clear under the sink prior to

arrival. Otherwise, remove supplies from under the sink and stack them neatly away from the working area. Arrange a light for the work area, if necessary.

If a basement installation is called for, determine where components will be located and how they will be mounted. Special mounting brackets and hardware may be necessary to secure the system to a wall or ceiling joists.

Inspect cold water supply line and drain to determine if any special fittings, in addition to what is included in the kit, are required.

#### *E. Prepare the Appliance for Installation*

Open shipping carton and remove components. Check that all installation parts are present which includes the purification assembly, storage tank, faucet, installation hardware, and tubing.

Check that the air supply in the empty tank is approximately 7 psi. Adjust if necessary.

## **SECTION IV. INSTALLATION STEPS**

All plumbing should be done in accordance with state and local plumbing codes.

**NOTE:** *Some codes may require installation by a licensed plumber; check with the local plumbing authority prior to installation.*

In restricted under-sink areas, it may be easier to install the faucet first. Allow adequate tubing lengths for any final component position.

## A. Install the Faucet

### See Figure 1 for Faucet Installation Diagram

The customer should be consulted before determining faucet location. The faucet should be positioned so that it empties into the sink and the spout swivels freely for convenience.

If the sink already has a hole provided that can accommodate the RO faucet, then no drilling is required and you can proceed to the section on mounting the faucet.

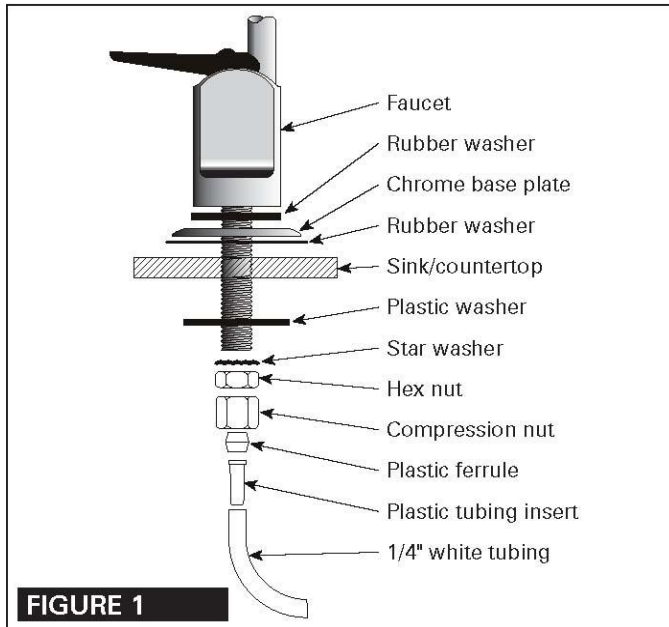

## 1. Make the Faucet Mounting Hole

**IMPORTANT:** It is mandatory that safety glasses be worn during sink hole drilling operations to prevent eye injury.

Before starting the hole making operation, always check below the sink so that nothing interferes with mounting the faucet such as reinforcing ribs, support brackets or cabinet construction.

### STAINLESS STEEL SINK:

Recommended tools:

- Center punch
- Variable speed drill and high speed drill bits.
- Greenlee chassis punch 7/8" hole size (alternate 9/16" size may be used for non air gap faucet)
- Protective gloves

Procedure:

- a) Center punch a small indent at the desired faucet location.

- b) Slowly drill the required pilot hole for the chassis punch.
- c) Set up the chassis punch per instructions and tighten nut to cut the desired hole size.
- d) Clean up sharp edges with a file if necessary.

### PORCELAIN/ENAMEL/CERAMIC ON SHEET METAL OR CAST IRON BASE:

Recommended tools:

- Variable speed drill
- Relton porcelain cutter tool set 7/8" size (alternate 9/16" size may be used for air gap or non-air gap faucet)
- Plumber's putty

It is important to understand what is involved in this procedure. First, the glassy layer of porcelain must be penetrated through to the base metal. Second, a center disc of porcelain must be removed while protecting the surrounding porcelain against chip ping or fracturing. Third, the base metal must be drilled through to complete the hole.

Procedure:

- a) Mark the center for the 7/8" hole
- b) Form shallow putty dam around hole area and fill with enough water to lubricate carbide drill bit.
- c) Carefully drill pilot hole through porcelain/enamel and base metal using carbide type pilot drill.

**IMPORTANT:** Always operate drill with light pressure at slow speed (300-400 rpm).

- d) Insert pilot tip of spring-loaded porcelain cutter into pilot hole.
- e) Drill porcelain/enamel using spring-loaded porcelain cutter, making certain a complete ring has been cut through the porcelain/enamel to the metal base.
- f) Change to the metal cutter. With slow speed and light pressure, cut away the inner porcelain/enamel disc down to base metal. Make certain that the cutter does not touch outer rim of the cut porcelain/enamel. Continue with this bit to cut through metal until sink has been completely penetrated.

**IMPORTANT:** When using a porcelain cutter it is critical to take precautions that it is always in a sharpened condition. Dull cutters are known to chip sinks.

## 2. Mount the Faucet:

- a) Familiarize yourself with all components shown in faucet diagram.
- b) Disassemble hardware from the threaded nipple, except for chrome base plate and rubber washer.

*NOTE: Rubber washer may be replaced with bead of plumber's putty for neater appearance.*

- c) Connect length of standard 1/4" tubing to faucet. Ensure plastic insert is in tubing. Push on firmly until it seats.
- d) Feed the threaded nipple through sink/counter mounting hole and orient the faucet as discussed with the customer.
- e) From below sink/counter assemble the black plastic washer, star washer and hex nut on threaded nipple and tighten by hand.
- f) After rechecking faucet orientation, tighten hex nut (9/16" wrench or deep socket) until faucet feels secure.
- g) From above the sink make any minor orientation corrections by turning the faucet with a padded adjustable wrench.
- h) Install plastic ferrule and compression nut on tubing.

*Note: Flats on chrome faucet may be used for tightening with an adjustable wrench. Use care not to mar chrome finish.*

## B. Install the Feed Water Valve and Tubing

The saddle tapping valve supplied is designed for use with 3/8" to 1/2" OD soft copper supply tubing (plain or chromed), rigid metal pipe, or CPVC plastic pipe. Do not use with flexible ribbed supply tubing which has too thin a wall thickness and requires special hard ware.

### Saddle Valve Installation

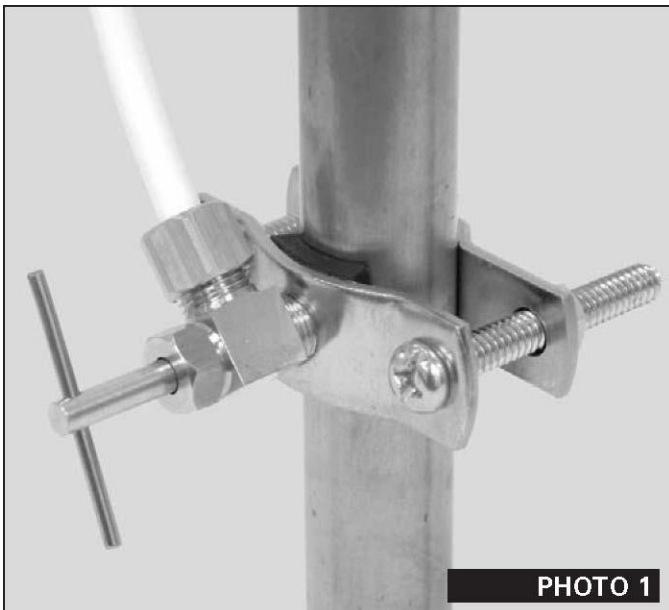

PHOTO 1

## SOFT COPPER TUBING INSTALLATION:

- 1) Turn off cold water valve under the sink, or main valve for the house.
- 2) Before installing saddle tapping valve, make sure piercing lance does not protrude beyond rubber gasket.
- 3) Assemble saddle tapping valve on copper tubing. Tighten clamp.
- 4) To pierce soft copper tube, turn handle clockwise until it is firmly seated. The valve is closed in this position.
- 5) Turn on main supply valve to pressurize coldwater line. Check for leaks. With a wrench snug nut/seal around valve stem.
- 6) Connect one end of the tubing to the feed water valve using brass compression nut and plastic sleeve.

*NOTE: For basement installations the existing feed water tubing may have to be longer to reach feed valve.*

## RIGID METAL PIPE AND CPVC PLASTIC PIPE INSTALLATION:

- 1) Turn off cold water supply valve and drain the line to prevent spillage.
- 2) Drill 3/16" hole at the desired location. To prevent shock hazard, use a battery operated drill.
- 3) Before installing saddle tapping valve, make sure piercing lance does not protrude beyond rubber gasket.
- 4) Assemble saddle tapping valve on copper tubing.
- 5) Turn saddle valve handle clockwise to close valve. With a wrench tighten nut/seal around valve stem.
- 6) When you wish to open valve and supply cold water to the unit, turn valve handle counter clock wise.
- 7) Connect one end of the tubing to the feed water valve using brass compression nut and plastic sleeve.

*NOTE: For basement installations the existing feed water tubing may have to be longer to reach feed valve.*

## C. Pre-fill and Sanitize the Storage Tank

Pre-filling the tank is always recommended so there is pressure to check for leaks and several gallons of water to flush carbon post filter. Tanks are furnished with a special disinfectant and only

require filling with water for 15 minutes to be completely sanitized. It is important to use a sanitizer when pre-filling tank so the solution can sanitize the tubing, fittings, and faucet at the time of installation and startup.

- 1) Insert free end of feed water tubing into the fitting on the storage tank.
- 2) Open feed water valve and tank valve and allow tank to fill (about 3 minutes).
- 3) Turn off feed water valve, tank valve, remove tank from tubing and set tank aside (15 minutes minimum).

#### D. Install the Drain Connection

**IMPORTANT:** Before starting this procedure, inspect the condition of the drain piping, especially in older homes where the traps and tailpieces can be deceptively thin and frail. If in poor condition, it is wise to inform the customer that the condition should be remedied.

The drain saddle assembly is designed to fit around a standard 1-1/2" OD drain pipe.

The drain saddle should always be installed above (before) the trap and on the vertical or horizontal tail piece. Never install the drain saddle close to the outlet of a garbage disposal or plugging of the RO drain line may occur.

- 1) Peel adhesive covering from the back of foam square gasket and line up with the hole in the saddle drain and apply. This gasket provides a leak proof seal on the drain stand pipe.
- 2) Position both halves of drain saddle at desired location on drain pipe.
- 3) Use bolts and nuts to clamp drain saddle onto drain pipe. Do not over tighten and make sure there is equal space between saddle halves on each side.
- 4) Carefully drill hole through threaded fitting of drain saddle (as shown in Photo 2) being careful not to drill through opposite side of drain pipe.
- 5) Insert drain tubing into compression nut and tighten onto drain saddle.

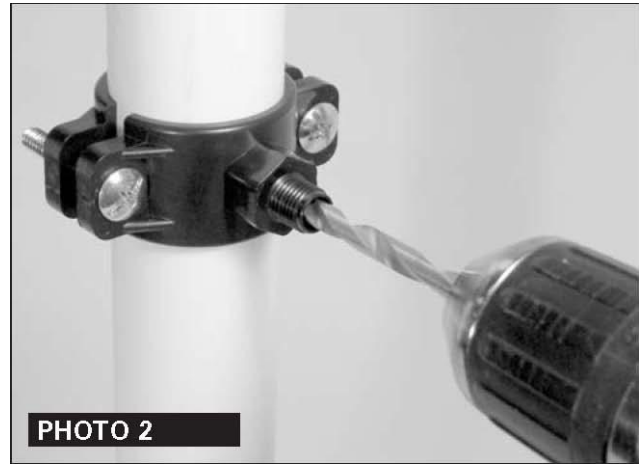

PHOTO 2

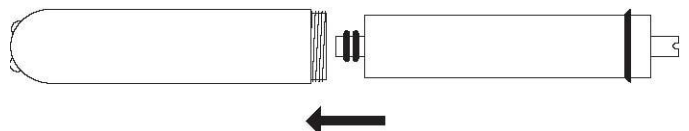

PHOTO 3

#### E. Install the R.O. Membrane

The RO Membrane has been shipped to you in a special preservative. Disconnect the tubing from the end cap of the membrane housing. Then, unscrew the end cap from the membrane housing on the appliance; insert the membrane as illustrated on the next page. The O-rings on the product water tube of the membrane **MUST FULLY SEAT** in the membrane housing for proper operation. Also make sure that the Brine Seal on the membrane seals with no gaps or wrinkles inside the membrane housing. Once the membrane is installed, replace the end cap and reconnect the tubing.

To insure that all the special preservative is flushed from the system before use, **DO NOT** use the first two tankfuls of water produced by the system.



## F. Make Initial Tubing Connections

It is advantageous to make some of the tubing connections at this time, since the under-sink work area is not so cramped and access to the components is easier.

## G. Install the Purification Assembly and Storage Assembly

The purification assembly is usually mounted to the right or left sink cabinet sidewall, taking into consideration the space available and the tank location. Generally, the tank is placed in the rear of the cabinet while the purification assembly is positioned toward the front for cartridge accessibility.

To mount the purification assembly elevate at least 2" off the cabinet floor and, while keeping level, mark the location of the mounting holes on cabinet sidewall. Make small pilot holes with an awl or drill and screw in the two mounting screws, leaving just enough protruding to allow bracket mounting slots to slide over them.

*NOTE: If the cabinet sidewalls are not of solid construction, the purification assembly can be set on the cabinet floor and held against the sidewall with the mounting screws.*

The tank may be oriented either vertically or horizontally. It is generally placed to the rear of the cabinet but can be set in the front center (between the sink basins) for ease of access if space permits.

## H. Make Final Tubing Connections

With all of the components in place, the final tubing connections can be made. When routing tubing between components, several guidelines should be observed.

- Tubing runs should generally follow the contour of the cabinets rather than interfere with the cabinet storage area.
- Strive for neatness and an orderly tubing "flow" using fasteners (e.g. insulated staples) to secure the tubing. Cut tubing to the desired length.
- Arrange the tubing so there are no sharp bends and leave some "play" in the tubing for ease of servicing.
- Try to keep the tubing from the purification assembly to the tank and faucet as short as practical for good flow.

## I. Install Ice Maker Hookup (optional)

*Note: Check with refrigerator manufacturer for compatibility with your refrigerator model.*

The RO drinking water appliance can be connected to any standard refrigerator ice maker or ice maker/water dispenser. It should never be connected to a commercial type bar ice maker.

Hooking up an ice maker involves connecting a tee with shut off valve into the faucet tubing and routing tubing over to the refrigerator. Do not hookup to existing copper tubing.

Before turning off the existing tap water supply to a refrigerator ice maker, always shut off the ice maker first (usually by lifting the lever arm above the bin to the upper most position). The ice maker should only be turned on again after the RO system has been drained several times and the tank has a full supply of water.

*NOTE: Before any service is performed on the RO system, always turn off ice maker valve and the ice maker unit. Only turn on when system is operating and tank is full.*

## J. Start up the System

- 1) Double check that all connections are secure.
- 2) Turn on feed water valve and check for leaks. If any leaks are noted, turn off valve and correct before proceeding.
- 3) Turn on storage tank valve and open faucet until a steady stream of water flows. Close faucet, wait at least 5 minutes and carefully check for leaks. Correct as necessary.

## K. Flush System of Preservative and Check Operation

- 1) Lift faucet handle and allow tank to drain completely of sanitizing solution. **DO NOT USE THIS WATER.** When tank is empty, the faucet will steadily drip. This is the rate water is processed by the RO system.
- 2) With faucet handle in "up" position, measure the rate of the steady drip from spout. Use a graduated cylinder (in milliliters) and watch with a second hand to calculate approximate production in gallons per day (milliliters per minute X 0.38 = gpd).

Proceed to check reject flow rate by disconnecting tubing at drain connection and measure as per above. The ratio should be a minimum of 2.5 (reject) to 1 (product).

- 3) Close faucet and re-inspect system for leaks. Instruct customer to wait at least 4 hours and drain tank again. The water should be discarded as it may contain some preservative/disinfectant solution.
- 4) System should be ready to use as soon as the tank refills. If any objectionable taste is noticed after second tank draining, instruct customer to wait and drain tank the following day. Only at this time should an ice maker be turned on if one is connected to the system.

## **SECTION V. OPERATION & MAINTENANCE**

### *A. Normal Operation*

- 1) It is normal for the Total Dissolved Solids (T.D.S.) of the water to be higher than normal during the first 5 gallons of operation; this is due to the sanitizing solution and the new Post Filter. After this water is rinsed to drain, the removal rate should stabilize at a value greater than 75%. Water pressure affects the production rate and quality.
- 2) R.O. systems produce drinking water at relatively slow rates; it can take up to 8 hours or more to fill the holding tank. Normal operation is to let the Holding Tank fill with water and then draw water as is needed. When the pressure in the Holding Tank falls to a given pressure (as the water is being used) the automatic shut-off valve (A.S.O. Valve) will start water production and the system will refill the Holding Tank. When the holding tank is full and no water is being used, the A.S.O. Valve will automatically shut off the feed water to conserve water.

The more water that is used (up to the capacity of the system) the better the R.O. system will function. Utilize other uses for the water, such as flowers, pets and rinsing glassware.

After periods of non-use, such as a week's vacation, it is better to empty the holding tank and allow the system to produce fresh water for use. If

the system is not used for 3-4 weeks or longer, it is a good idea to re-sanitize the system and to change the Activated Carbon and Sediment Filters.

### *B. Changing Filter*

**NOTE: THIS R.O. SYSTEM CONTAINS FILTERS WHICH MUST BE REPLACED AT REGULAR INTERVALS TO MAINTAIN PROPER PERFORMANCE. USE ONLY FACTORY APPROVED FILTERS.**

Please see Page 3 for the recommended interval for changing the filters. Local conditions may dictate more frequent changes.

Use a drip pan to catch any water that may spill when the filter housings are removed:

- 1) Close plastic supply valve located on the inlet line of the system.
- 2) Close the valve on the inlet of the storage tank.
- 3) Open the faucet and wait for the flow to stop.
- 4) The pre-membrane cartridges can be hinged out away from the wall. Rotate the cartridge 1/4 turn counter clockwise and pull down. The cartridges can be disposed.
- 5) Push the new filter into the head and rotate it clockwise ¼ turn.
- 6) Wipe up any spilled water.
- 7) To change the in-line post filter refer to the section dealing with quick connect fittings.

**RESIDENTIAL REVERSE OSMOSIS SYSTEM DIAGRAM**

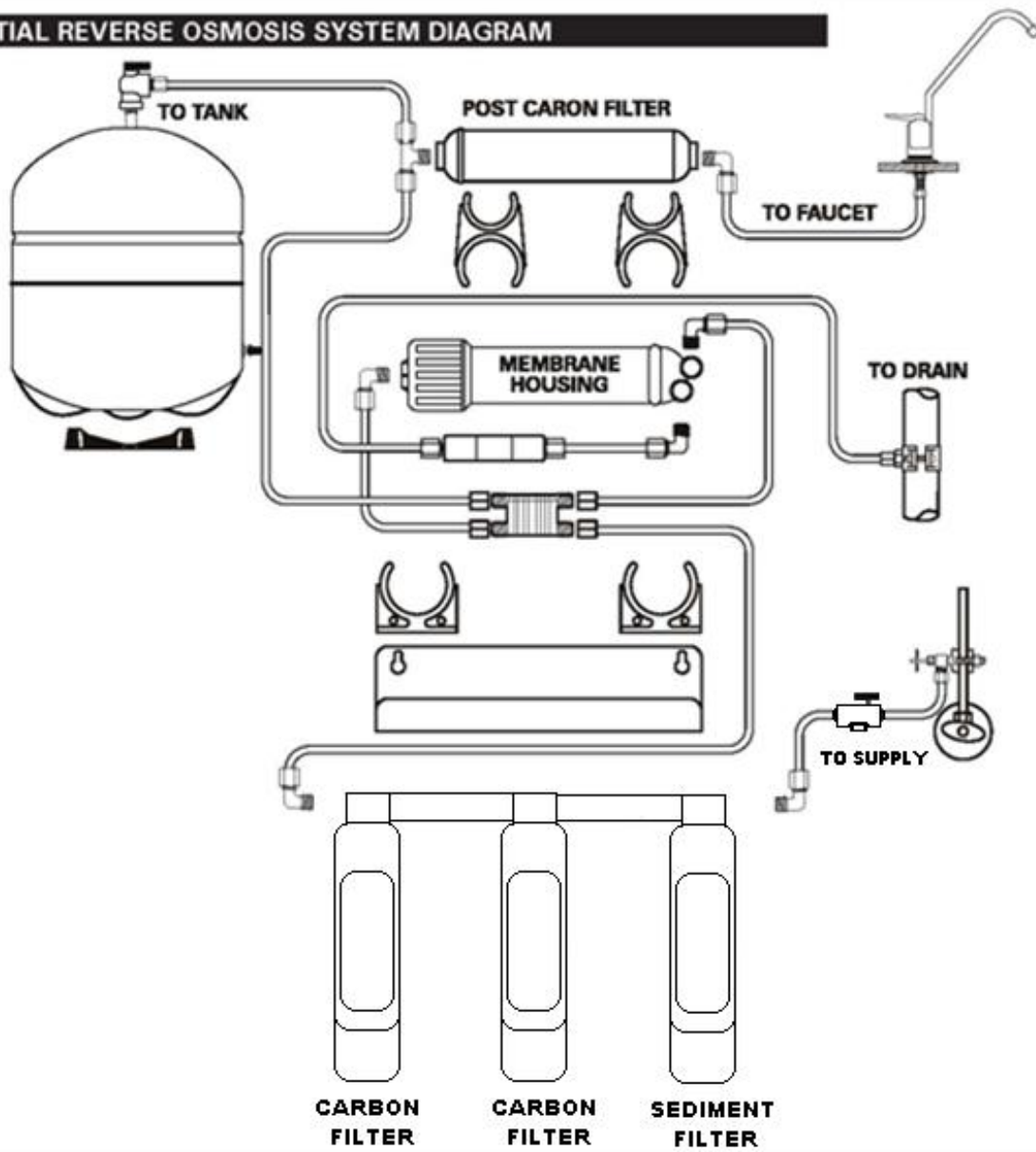

### C. For System Equipped with Quick Connect Fittings

Your new Reverse Osmosis Drinking Water Appliance may be outfitted with new generation of user-friendly quick connect push-in fittings. Proper use of the fittings is shown in the diagrams.

It is important that the tubing selected for use with these connectors be of high quality exact size and roundness, and with no surface nicks or scratches. If it is necessary to cut the tubing, use a plastic tubing cutter or sharp razor knife. Make a clean, square cut.

An optional blue locking clip is installed in certain fittings to provide extra security. Remove this clip first before trying to remove tubing by sliding away from fitting.

Should a leak occur at a fitting, the cause is usually defective tubing.

To fix:

- Relieve pressure
- Release tubing
- Cut off at least ¼" from end
- Reattach tubing
- Confirm connection is leak free

### TO ATTACH TUBING...

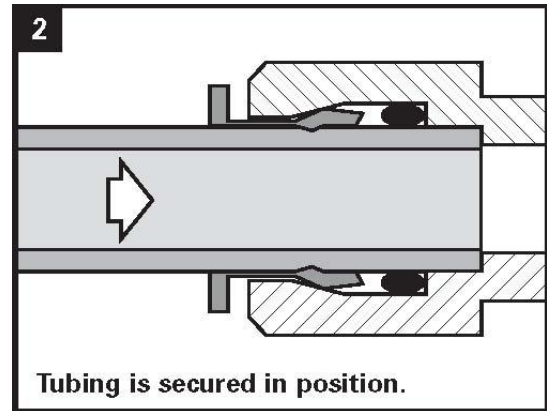
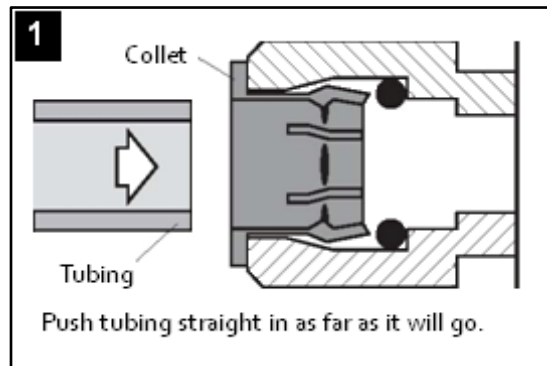

### TO RELEASE TUBING...

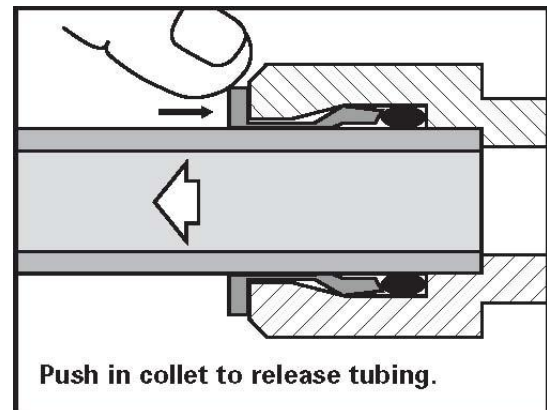

## SECTION VI. TROUBLE SHOOTING GUIDE

<b>Problem</b>	<b>Possible Cause</b>	<b>Solution</b>
<b>Low quantity of Product Water from Holding Tank</b>	Feed Water Saddle Valve is plugged or closed.	Open Valve or unclog.
	Clogged Sediment Prefilter or Activated Carbon Prefilter.	Replace filters.
	Low water pressure	Feed Water pressure must be above 40 psig.
	R.O. Membrane is fouled.	See Feed Water operating limits. Correct cause of fouling, replace Membrane.
	Plugged In-Line Activated Carbon Post Filter.	Replace Post Filter.
	Air precharge pressure in Holding Tank is too high.	Empty water from Holding Tank, and with the faucet open, adjust air pressure to 5–7 psig (5–8k Pa) range.
	Air precharge is too low.	
	Air bladder in the Holding Tank is ruptured.	Replace tank.
	Holding Tank Valve is closed.	Open Valve.
	No drain flow, the Drain Restrictor is plugged.	Clear or replace Drain Restrictor.
	The Check Valve is stuck.	Free check valve.
	The ASO Valve is malfunctioning.	Replace ASO Valve components.
	In-Line Activated Carbon Post Filter is plugged.	Replace Post Filter.
<b>Low pressure at the Dispensing Faucet</b>	Air precharge in the Holding Tank is too low.	Empty water from Holding Tank and with the faucet open, adjust the air pressure to 5–7 psig (5–8 kPa) range.
	Holding Tank Valve is partially closed.	Check for leak age at the Air Valve Stem.
		Open Valve.
	The Dispensing Faucet is out of adjustment or faulty.	Repair or replace Dispensing Faucet.
	Heavy water use, Holding Tank is depleted.	Allow Holding Tank to refill (adding a second Holding Tank will increase storage capacity).
	Low Water Production.	See Low Quantity of Product Water from Holding Tank section above
	Clogged Sediment Prefilter or Activated Carbon Prefilter.	Replace Filters.
<b>High Total Dissolved Solids (TDS) in the Product Water</b>	Low Water Pressure.	Feed Water Pressure must be above 40 psig.
	R.O. Membrane O–ring is crimped.	Check Feed Water Saddle Valve.
		Check O–ring.
	R.O. Membrane brine seal is not sealing up into the manifold head.	Check the brine seal.
R.O. Membrane is expended.	Replace Membrane. Check operating limits.	

<b>Problem</b>	<b>Possible Cause</b>	<b>Solution</b>
<b>High Total Dissolved Solids (TDS) in the Product Water (continued)</b>	The Product Water and Drain Water lines are reversed.	Correct plumbing.
	No drain flow, Drain Restrictor is clogged.	Clear or replace Drain Restrictor.
	No drain flow, the drain orifice in the Dispensing Faucet is plugged.	Clear or replace Dispensing Faucet.
	The ASO Valve is not closing.	Repair or replace the ASO Valve Components.
	New In-Line or Activated Carbon Prefilter not rinsed completely.	Flush with several full tanks of Product Water.
	The Feed Water TDS has increased.	An increase in Feed Water TDS will give a corresponding increase in Product Water TDS.
<b>Tastes and odors in the Product Water</b>	The In-Line or Activated Carbon Prefilter is exhausted.	Replace Filters.
	There is foreign matter in the Holding Tank.	Clean, flush and sanitize the system. Replace the filters.
	The Product Water and Drain Water lines are reversed.	Correct plumbing.
	Dissolved gasses in the Feed Water.	Pretreat Feed Water to remove dissolved gasses.
	Increase in Product Water TDS.	See high TDS in the Product Water section.
<b>Faucet leaks or drips</b>	Leaks from base of the delivery tube.	O-ring is bad, replace O-ring.
<b>Fitting leaks in general</b>	Close the Feed Water Saddle Valve and relieve pressure before disconnecting any tubing or replacing any fitting. Before replacing a fitting, re-cut the tubing and re-insert into the fitting to see if that solves the leak. If pipe threads are leaking, remove and retape with Teflon tape.	



## **R.O. DRINKING WATER SYSTEM LIMITED WARRANTY**

### **What Does This Warranty Cover?**

*This warranty covers any defects in materials and workmanship of the R.O. Drinking Water System when installed and operated within recommended parameters, with the exceptions stated below.*

### **How Long Does The Coverage Last?**

*The manufacturer will warrant its R.O. Drinking Water System, for a period of one year from the date of purchase. All implied warranties including merchantability and fitness for a particular purpose are limited to one year from the date of purchase for the R.O. Drinking Water System. Some states do not allow limitations on how long an implied warranty lasts, so the above limitations may not apply to you.*

### **What Will The Manufacturer Do?**

*The manufacturer will repair or replace at its discretion any defective component. You must pay any labor charges. You must also pay for shipping or travel charges to return the defective part(s).*

### **What Does This Warranty Not Cover?**

*This warranty does not cover the disposable sediment and carbon filters whose service life depends on feed water conditions. In addition, the membrane is only warranted if the required feed water conditions are met.*

*The above warranty will also not apply to any part of the R.O. Drinking Water System that is damaged because of neglect, misuse, alterations, accident, misapplication, physical damage, or damage caused by fire, acts of God, freezing or hot waters or similar causes. Consequential and incidental damages are not recoverable under this warranty. Some states do not allow the exclusion or limitation of incidental or consequential damages, so the above limitation or exclusion may not apply to you.*

*We recommend that you use only the manufacturer's replacement parts since improper parts or incorrectly performed maintenance or repair voids this warranty.*

### **How Do You Get Service?**

*In order to be eligible for service under this warranty you must (a) contact your local dealer who supplied the unit.*

### **How Does State Law Apply?**

*This warranty gives you specific legal rights and you may also have other rights which vary from state to state.*